



KUSCH
Engineered.

Seismic Brace Installation Details

Mechanical Services

January 2025

NOTE: ANY SUBSTITUTION MUST BE APPROVED BY KUSCH PRIOR TO INSTALLATION

SECTION		BRACE TYPE		PAGE No.
1. SCHEDULES				
1.1	GENERAL - TYPICAL	ALL CABLE TYPES	CABLE BRACE COMPONENT SCHEDULE	3
1.2	GENERAL - TYPICAL	ALL POST & STRUT TYPES	STRUT BRACE COMPONENT SCHEDULE	4
2. OVERALL PRINCIPLES				
2.1	GENERAL - TYPICAL	ALL TYPES / TRADES / SERVICES	TYPICAL INSTALLATION PRINCIPLES	5
3. TYPICAL BRACE DETAILS				
3.1	GENERAL - TYPICAL	ALL CABLE TYPES	CABLE BRACE INSTALLATION ANGLES	6
3.2	GENERAL - TYPICAL	ALL CABLE TYPES	CABLE BRACE CONNECTION TO PURLIN/TRUSS	7
3.3	GENERAL - TYPICAL	ALL CABLE TYPES	HANGER TO PURLIN CONNECTION	8
3.4	GENERAL - TYPICAL	ALL CABLE TYPES	CABLE BRACE INSTALLATION - JOINING CABLES	9
3.5	GENERAL - TYPICAL	ALL TYPICAL TRAPEZE	TRAPEZE CONNECTION DETAILS	10
3.6	GENERAL - TYPICAL	ALL CABLE TYPES	CABLE BRACE ANCHORS	11
3.7	GENERAL - TYPICAL	ALL CABLE TYPES	ROD STIFFENER INSTALLATION	12
4. CABLE BRACES				
4.1	CABLE KIT INSTALLATION	9, 11, 13	TWO-WAY CABLE BRACE	13
4.2	CABLE KIT INSTALLATION	19	TWO-WAY CABLE BRACE	14
4.3	TRAPEZE WITH CABLE BRACE	10, 12, 14, 18 & 20	FOUR-WAY CABLE BRACE	15
4.4	TRAPEZE WITH CABLE BRACE	22, 24, 25 & 26	FOUR-WAY CABLE BRACE - SPLIT	16
4.5	CABLE BRACE	FAN, FCU.	FOUR-WAY CABLE BRACE - SPLIT FCU & FAN	17
4.6	STRUT WITH CABLE	P4C	P4C - WALL FIXED STRUT WITH CABLE	18
5. CANTILEVER POST BRACES				
5.1	SP50 POST (WELDED)	K1, K1f	K1 - SP50 CANTILEVER POST	19
5.1	SP50 POST (WELDED)	K1, K1f	K1 - SP50 CANTILEVER POST	20
5.2	SP50 POST (WELDED)	K1 (TRAPEZE)	K1 - SP50 POST WITH STRUT TRAPEZE	21
5.3	41mm STRUT POST	C2 & C3	C2 & C3 - CANTILEVER STRUT POST	22
5.4	SP50, SP80 & SP100 POSTS	J1-3, HI-3, G1-3	SP50, SP80 & SP100 POSTS	23
6. STRUT BRACES				
6.1	WALL MOUNTED	P1, P3, P4 & P4T	P1,3,4 & 4T - WALL FIXED STRUT BRACES	24
6.2	WALL MOUNTED	P6, P9 & P9C	P6, 9 & 9C - STRUT BRACES	25
6.3	STRUT BRACE TO TRAPEZE	P8	P8 - STRUT BRACE TO SOFFIT	26
6.4	STRUT WITH CABLE	S50	S50 - WALL FIXED SP50 WITH CABLE	27
7. EQUIPMENT RESTRAINT				
7.1	FLOOR MOUNTED	FIXING DETAIL	FLOOR MOUNTED MECHANICAL EQUIPMENT	28

CABLE BRACE COMPONENT SCHEDULE

A COMPLETE BILL OF MATERIALS AND FULL COORDINATION CAN BE ACHIEVED WHEN THE PROJECT IS MODELED IN REVIT. HERE IS AN EXAMPLE SCHEDULE OF FAMILIES IN A PROJECT AND COMPONENTS WITHIN EACH FAMILY.

CABLE BRACE SCHEDULE MECHANICAL													
FAMILY	TYPE	Id#	CABLE KIT COLOUR	M10 ROD	41mm STRUT TRAPEZE + STIFFENER STRUT	2m CABLE Qty	3m CABLE Qty	5m CABLE Qty	ROD STIFFENER FIXING	CABLE ANCHORS	ROD ANCHORS	41mm STRUT WASHER	M10 HEXNUT
DUCT 2WAY	9	M- 001	B	1720	1025	2	0	0	0	2	2	4	4
DUCT 4WAY	10	M- 002	B	2640	3690	4	0	0	6	4	2	4	4
DUCT 2WAY MID INTERNAL	13	M- 003	G	2640	1025	2	0	0	0	2	2	4	4
DUCT 4WAY MID INTERNAL	14	M- 004	G	2640	1025	4	0	0	0	4	2	8	8
PIPE 2WAY	15	M- 005	B	4110	2940	2	0	0	8	2	2	4	4
PIPE 4WAY	16	M- 006	B	3630	2700	4	0	0	6	4	2	4	4
PIPE 2WAY INTERNAL	17	M- 007	R	1720	1025	2	0	0	0	2	2	4	4
PIPE 4WAY INTERNAL	18	M- 008	R	1720	1025	4	0	0	0	4	2	4	4
FCU_FAN SPLIT 4WAY	F	M- 009	G	1720	1025	2	0	0	0	2	2	4	4
FCU_FAN SPLIT 4WAY INTERNAL	F	M- 010	G	1720	1025	2	0	0	0	2	2	4	4
DUCT SPLIT 4WAY	22	M- 011	B	1720	1025	2	0	0	0	2	2	4	4
DUCT SPLIT 4WAY MID INTERNAL	25	M- 012	B	2640	1025	2	0	0	0	2	2	4	4

UNIQUE ID ENGINEERS' SPECIFICATION VALUES WILL VARY WITH EACH INSTANCE BILL OF MATERIALS FOR EACH TYPE

'Id#' IS A UNIQUE IDENTIFIER ASSIGNED TO EACH INSTANCE WITHIN A PROJECT TO AID IN QUALITY ASSURANCE, INSTALLATION TRACKING AND INSPECTION. THE Id# WILL BE TAGGED TO THE INSTANCE OF A BRACE FAMILY ON A PLAN VIEW.

EXAMPLE PROJECT PLAN VIEW, MODELED BRACE FAMILY WITH TRIMBLE POINTS AND Id TAGS.

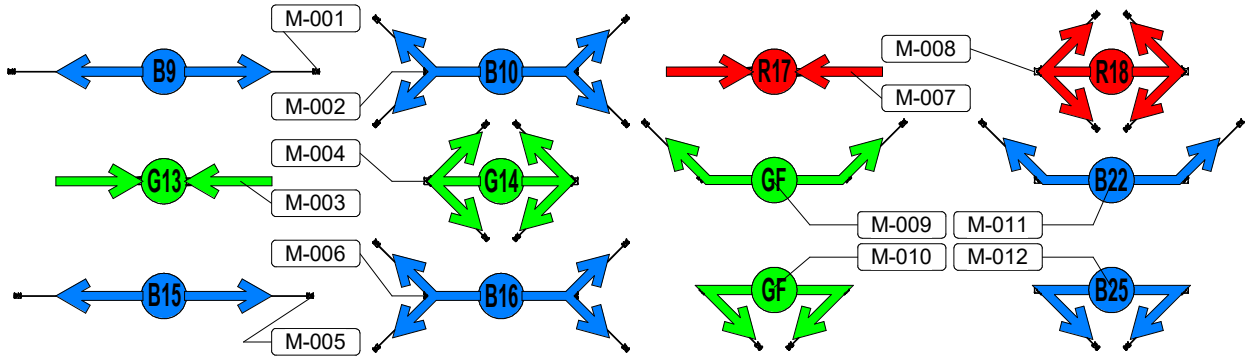

2D PDF DESIGN MARKUP, BRACE SYMBOL EXPLANATION.

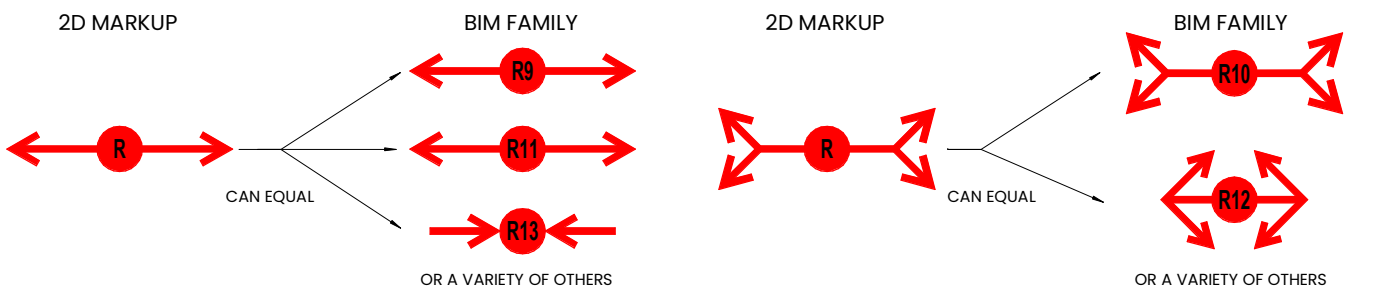

TWO-WAY CABLE KITS OF THE SAME KIT COLOUR ARE INTERCHANGEABLE WITH THESE CONFIGURATIONS: TYPICAL, MID-MOUNT, INTERNAL.

FOUR-WAY CABLE KITS OF THE SAME KIT COLOUR ARE INTERCHANGEABLE WITH THESE CONFIGURATIONS: TYPICAL, MID-MOUNT, INTERNAL.

STRUT BRACE COMPONENT SCHEDULE

A COMPLETE BILL OF MATERIALS AND FULL COORDINATION CAN BE ACHIEVED WHEN THE PROJECT IS MODELED IN REVIT. HERE IS AN EXAMPLE SCHEDULE OF FAMILIES IN A PROJECT AND COMPONENTS WITHIN EACH FAMILY.

STRUT BRACE SCHEDULE																															
FAMILY	TYPE	Id#	M10 ROD	41mm STRUT	50x5 SLOTTED EA	K1_750	K1_1000	K1_1500	FM1026	FM2346	FM2324	FM2072	FM1546	FM1346	FM1036	FM1031	FM1008	41mm STRUT WASHER	SP50	SP80	SP100	SP50 2072 BASEPLATE	SP80 2072 BASEPLATE	SP100 2072 BASEPLATE	SPBOLT M10S	SPBOLT M12S	BASEPLATE ANCHORS	M10x35 HEXHEAD BOLT	M10 HEXNUT		
C2 POST	C2	M- 001		600	0							0					0										4	0			
C3 DUCT	C3	M- 002		520																							4				
P1	P1	M- 004		1000					2	0				0			2												2		
P1 to Steel	P1	M- 005		995					0	0				2			2												2		
P1 STANDOFF_3LEG	P3	M- 006		1880					0	3	0			0	2	1	10												10		
P4	P4	M- 007		933					1					0			1												1		
P4T	P4T	M- 008		2041					2	1				0			5												5		
P6 DUCT	P6	M- 009		1000					1	0				0			2												1		
P8	P8	M- 010	1640	1127										2			2												2	2	
P8	P8	M- 011	1640	1127										2			2												2	2	
P9	P9	M- 012		1076					2	0				0			2												2		
K1 POST w_EA	K1	M- 013		0	1000	0	0	1	0								0	2											4	0	
K1 POST w_STRUT	K1	M- 014		1000	0	0	0	1	0								2	2												4	0
K1 TRAPEZE to Wall_DOUBLE	KIT	M- 015		1410		0	0	1	4								4													6	4
K1 TRAPEZE to Wall_SINGLE	KIT	M- 016		574		0	0	1	2								2													5	2
K1 TRAPEZE DOUBLE TALL	KIT	M- 017		5548		0	0	2	4								4													8	8
G1 POST	G1	M- 018		0															3000				2		2					8	
J2 POST	J2	M- 019		0																1200				1		6				4	
H3 HURDLE	H3	M- 020																				3820		2		28				8	

UNIQUE ID VALUES WILL VARY WITH EACH INSTANCE BILL OF MATERIALS FOR EACH TYPE VALUES WILL VARY WITH EACH INSTANCE BILL OF MATERIALS FOR EACH TYPE

'Id#' IS A UNIQUE IDENTIFIER ASSIGNED TO EACH INSTANCE WITHIN A PROJECT TO AID IN QUALITY ASSURANCE, INSTALLATION TRACKING AND INSPECTION. THE Id# WILL BE TAGGED TO THE INSTANCE OF A BRACE FAMILY ON A PLAN VIEW (EXAMPLE BELOW).

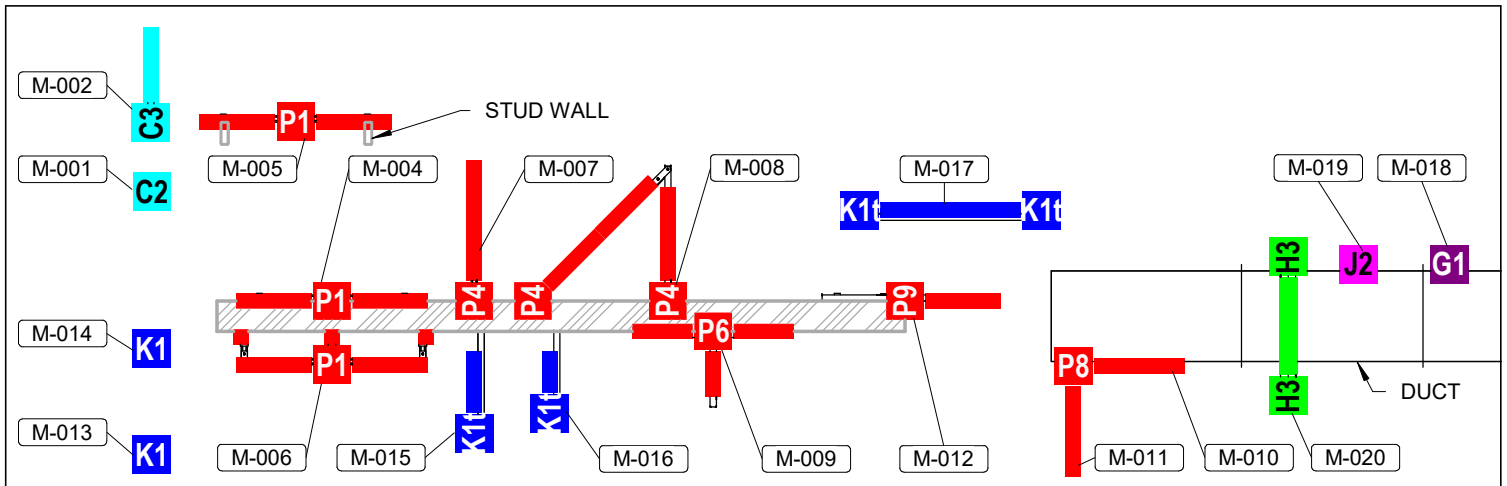

TYPICAL INSTALLATION PRINCIPLES

AT EVERY INSTANCE, USE:

- SEISMIC RATED CONCRETE ANCHORS AS APPROVED BY KUSCH
- 41mm STRUT WASHER AND LOCKING NUT ABOVE AND BELOW TRAPEZE
- STIFFENERS TO ROD IF LONGER THAN 750mm.
- M10 (MINIMUM) ROD HANGERS

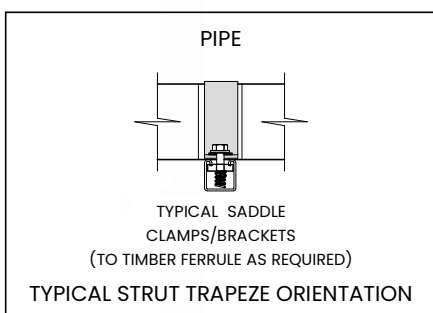
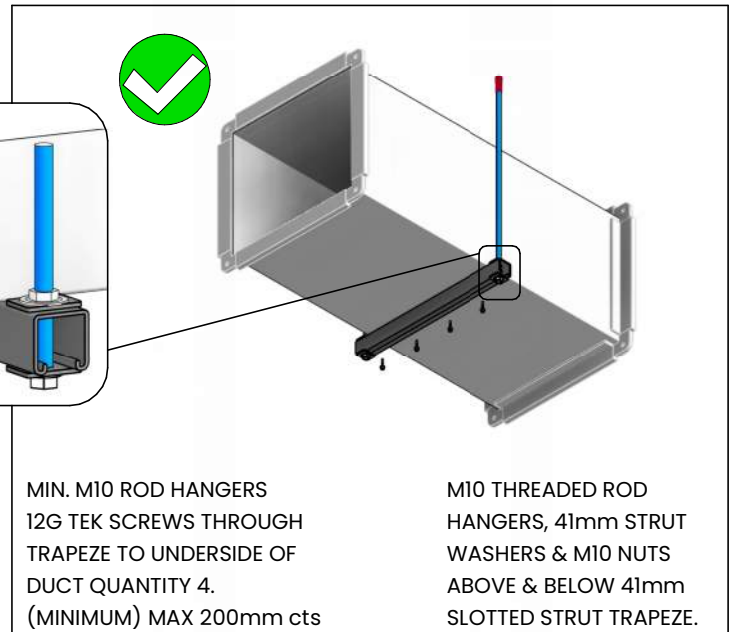
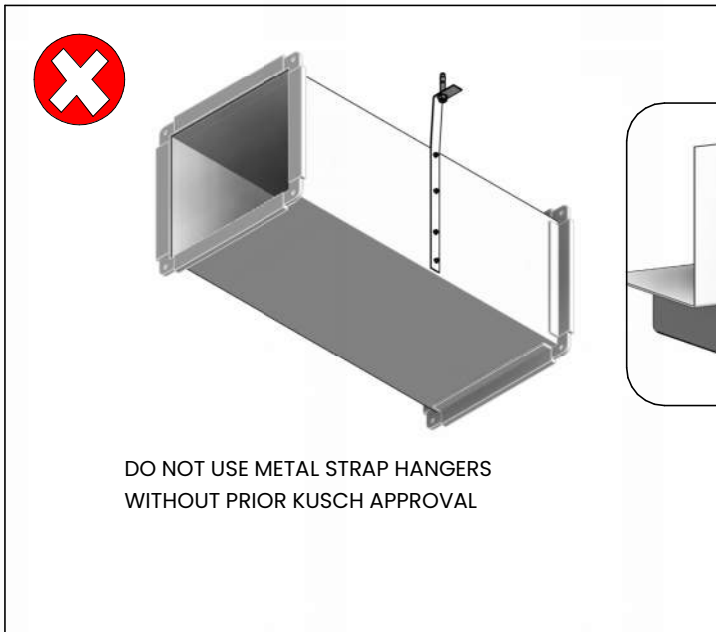
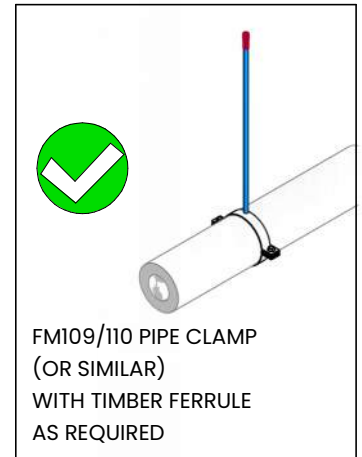
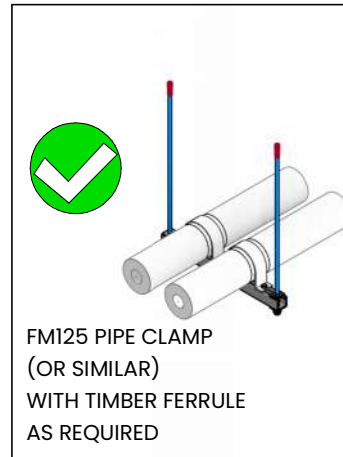
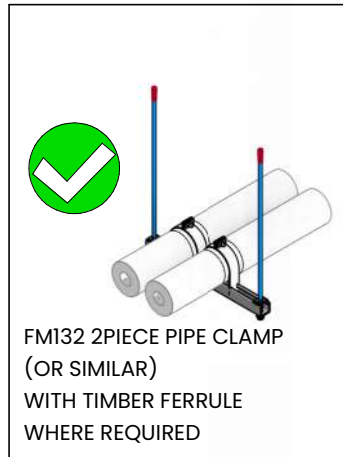

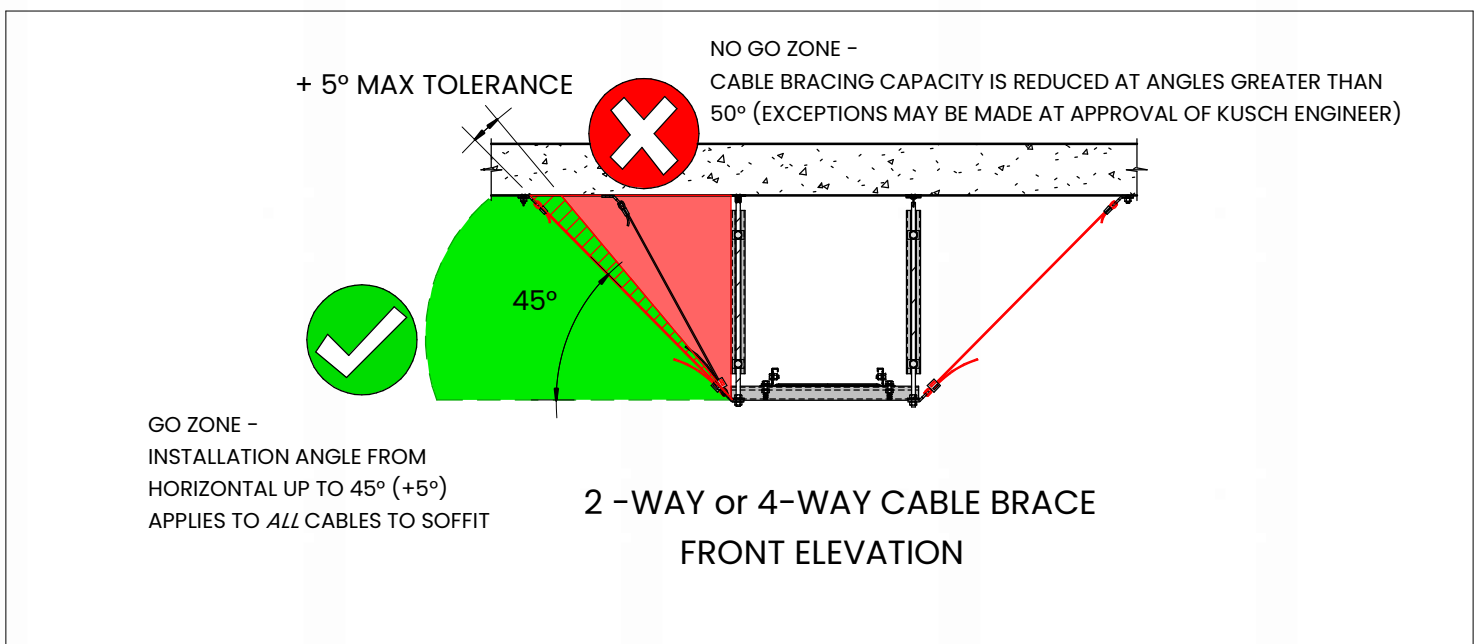
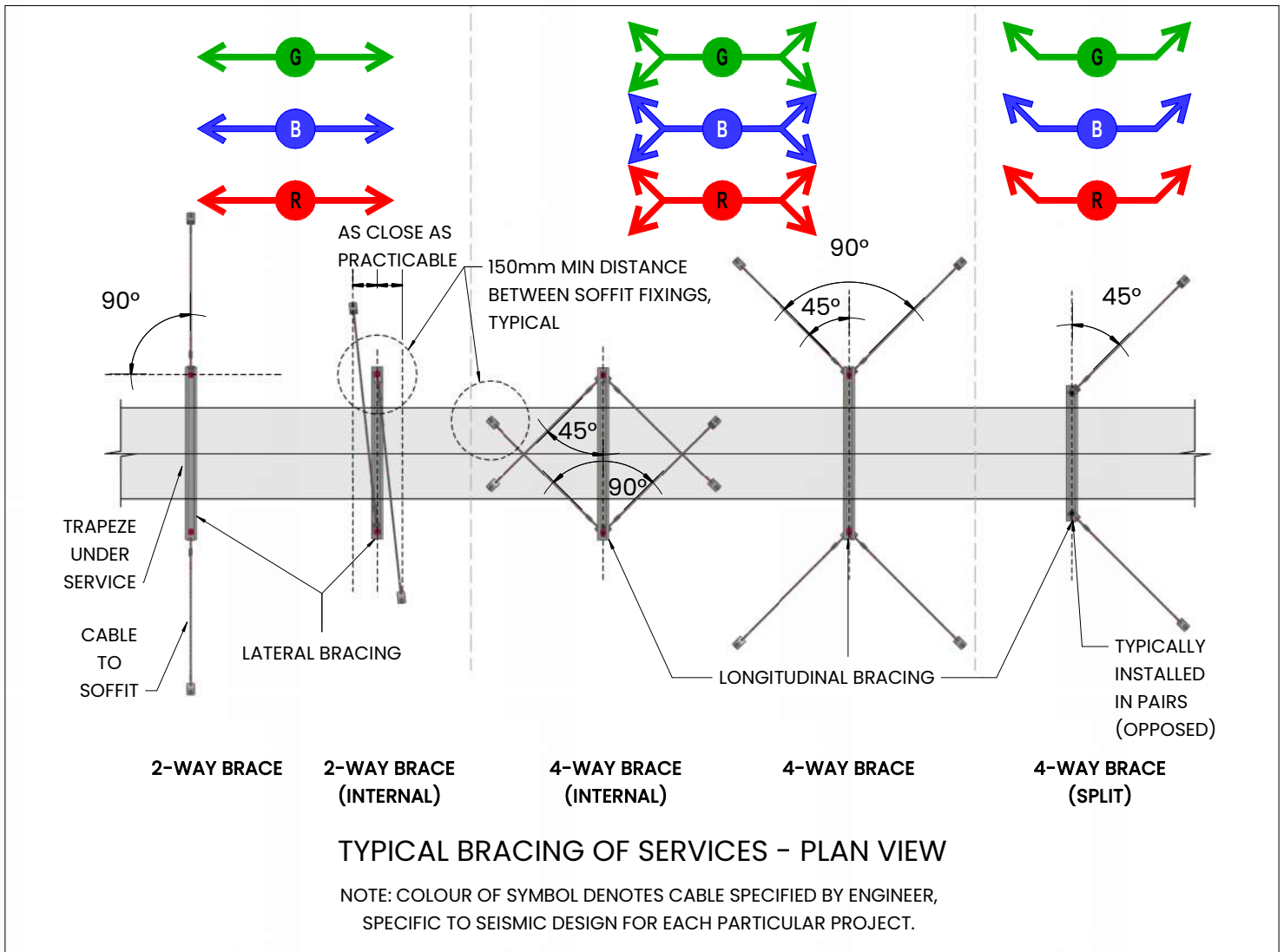

CABLE BRACE CONNECTION TO PURLIN/TRUSS

SEISMIC CABLE TO PURLIN CONNECTION DETAIL

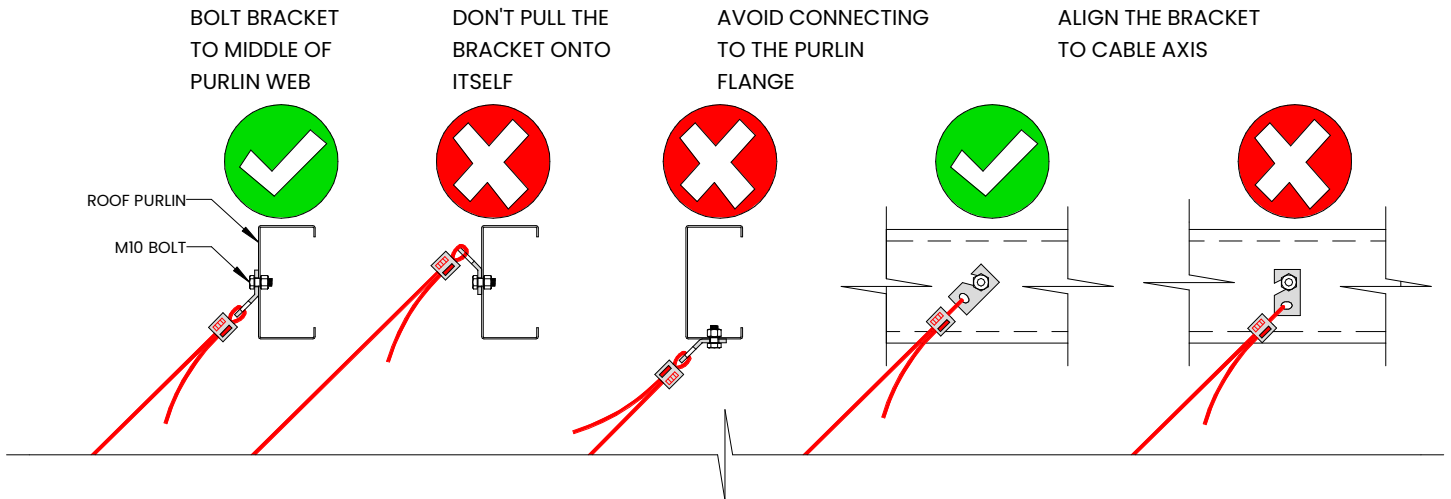

SEISMIC CABLE TO TIMBER TRUSS CONNECTION DETAIL

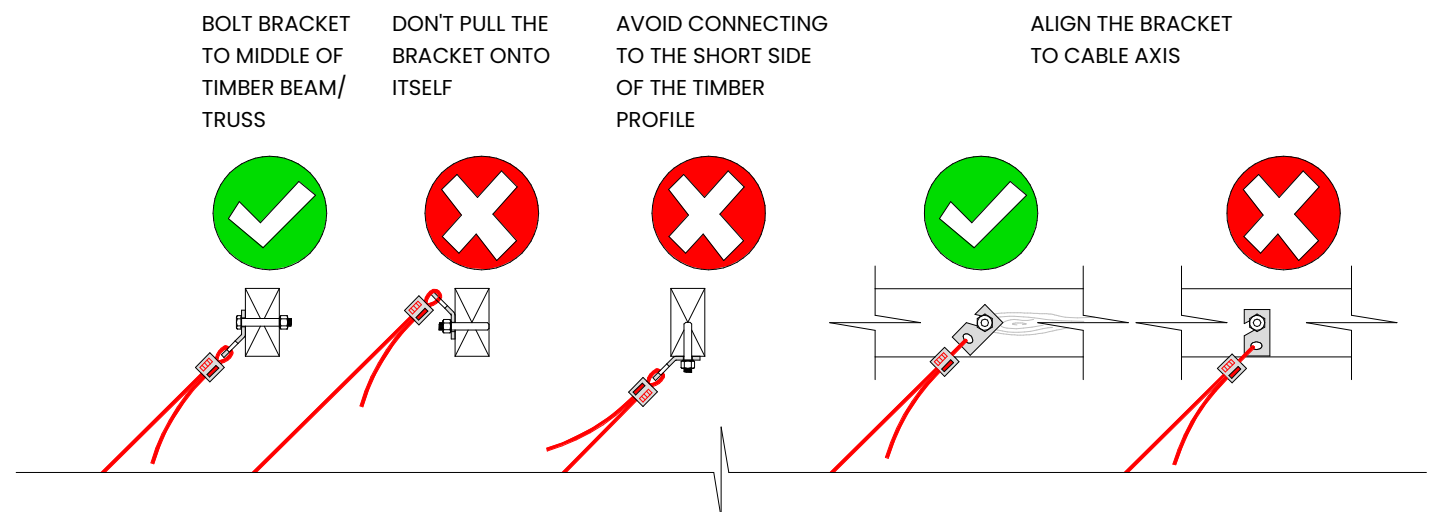

IMPORTANT!

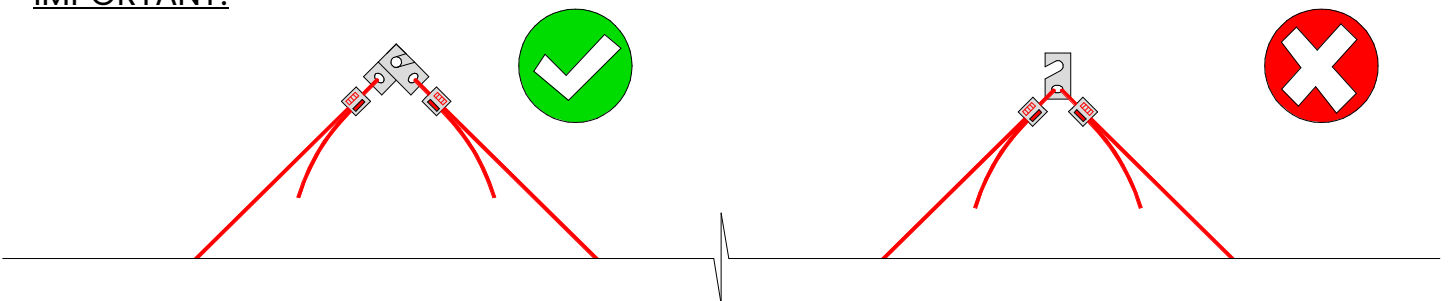

DO:

- HAND TIGHTEN CABLE USING ZIP-CLIP CABLE JOINER.
- ADJUST Zip-Clip CABLE JOINER USING RELEASE PINS IF REQUIRED.
- LEAVE A TAIL AT FREE END OF CABLE PASSING THROUGH Zip-Clip CABLE JOINER, MIN. 150mm.
- ALIGN 45° ANGLE BRACKETS AT EACH END SO THAT BOTH HOLES ON ANGLE BRACKETS ARE IN LINE WITH CABLE, AND CABLE IS PULLING ON NEAREST HOLE.
- USE ROD STIFFENERS FOR HANGING RODS >750mm LONG.

DO NOT:

- DO NOT ALLOW CABLE TO CONTACT ANY SERVICE, STRUCTURE, PLANT, HANGING ROD, BRACE ETC. ALONG ITS ENTIRE LENGTH.
- DO NOT ATTACH 2off OR MORE CABLES TO 1off SB /NR 45° ANGLE BRACKET.
- DO NOT OVER-TIGHTEN CABLE IN ABSENCE OF ROD-STIFFENER. IF HANGING ROD BUCKLES, THE CABLE CANNOT PROVIDE ADEQUATE RESTRAINT.
- DO NOT BOLT 45° BRACKETS TO PURLIN FLANGES.

SERVICE HANGER DIRECTLY FROM PURLIN

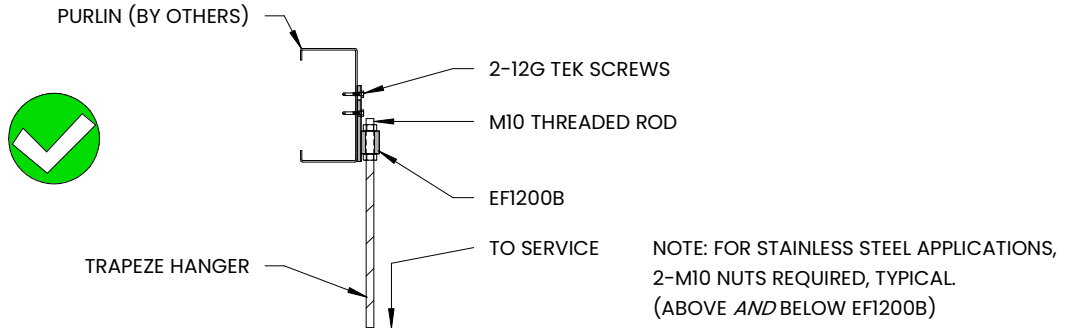

WHERE SERVICE HANGER IS NOT DIRECTLY BELOW PURLIN

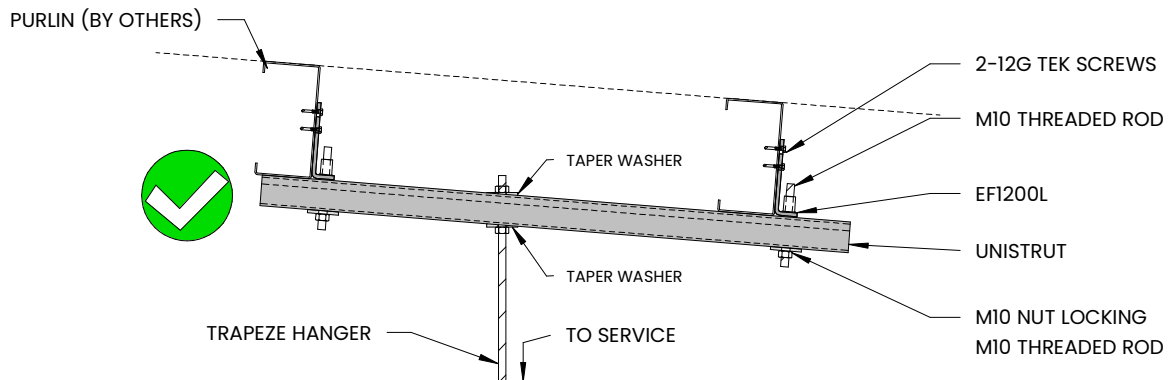
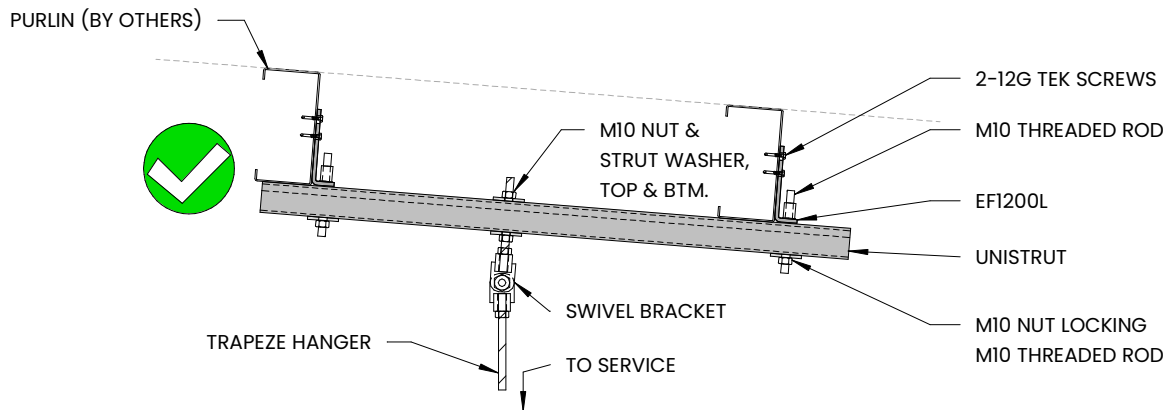
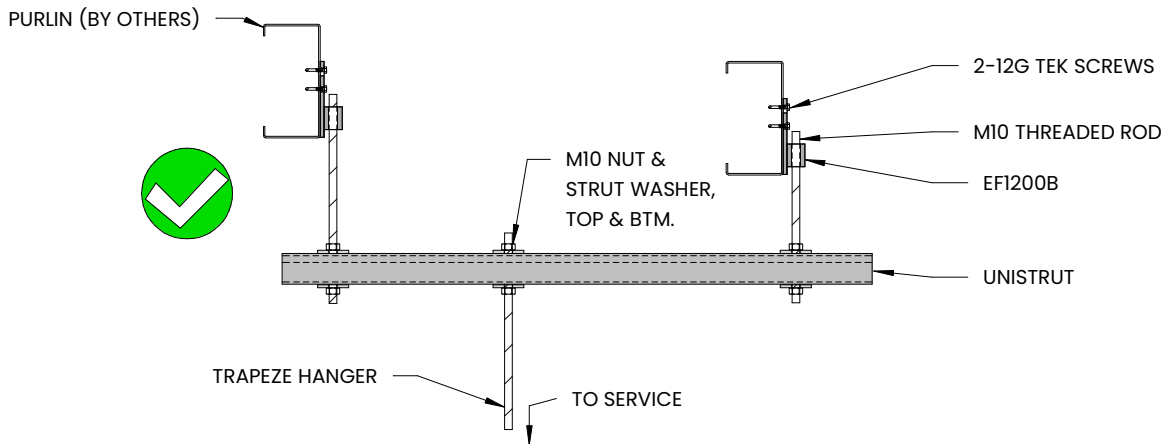

CABLE BRACE INSTALLATION - JOINING CABLES

OPTION 1: ELIMINATE BRACKET AND JOIN LOOP-TO-LOOP

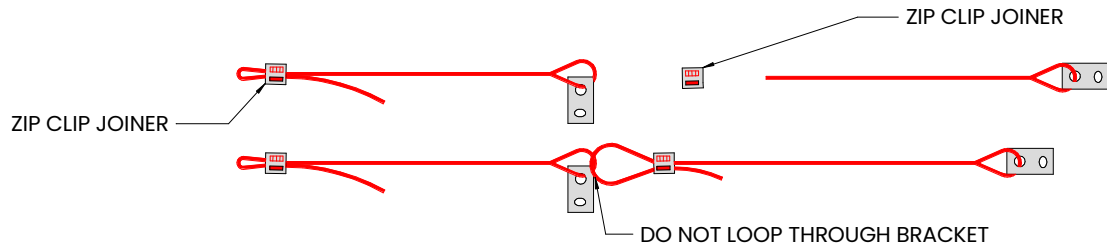

OPTION 2: ELIMINATE BRACKET, REMOVE FIXED LOOP WITH WIRE CUTTERS AND JOIN WITH ZIP CLIP JOINER

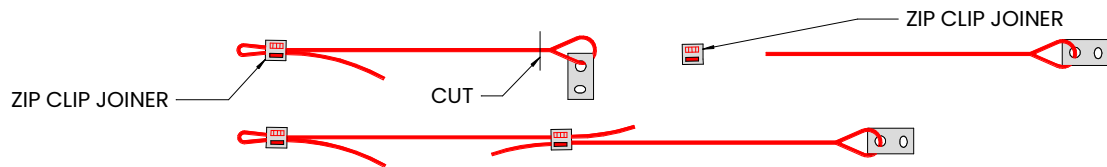

PIPE AND TRAY TRAPEZE DETAIL SECTION

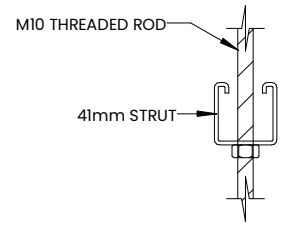
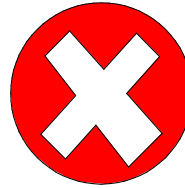
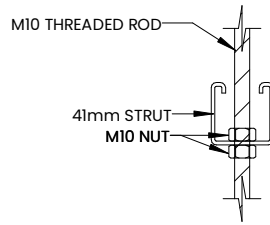
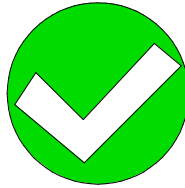
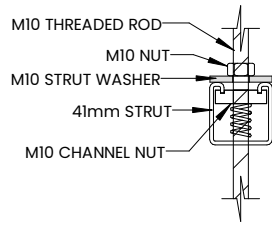
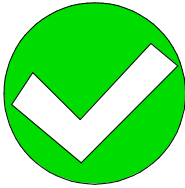
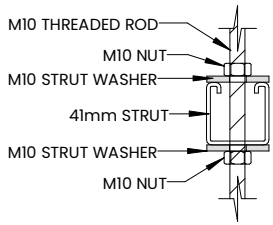



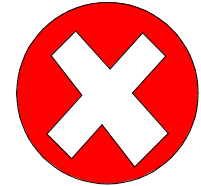
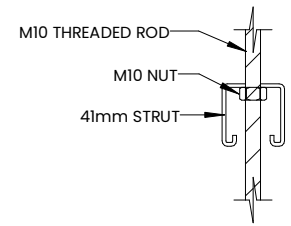
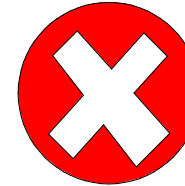
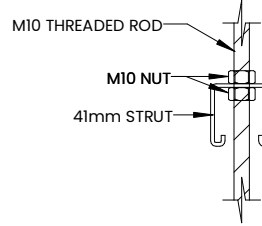
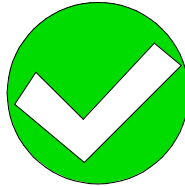
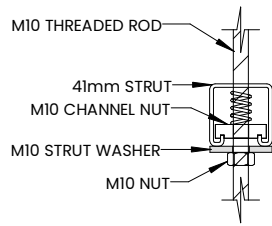
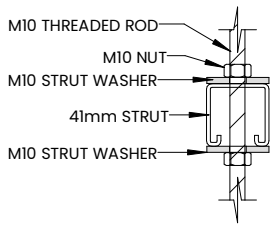



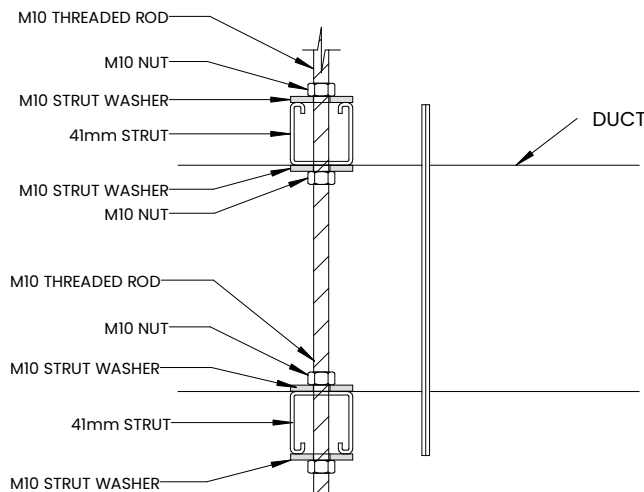
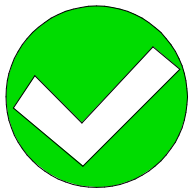

DUCT TRAPEZE DETAIL SECTION



MID-HEIGHT DUCT TRAPEZE DETAIL SECTION



 ZIP-CLIP SEISMIC RATED BRACE SCHEDULE C1 ANCHORS Brace Angle MAX 45°					
BRACE SYMBOL	Zip-Clip Cable Type	DEWALT Slab Connection	ICCONS Thru-bolt Slab Connection	HILTI HST3	ICCONS FM753 Slab Connection
	RED (2mm)	M10x90 PTB-ETA1-PRO	M10x90 Thru-bolt	M10x90 HST3	M10x90 ICCONS-FM753
	BLUE (3mm)		M12x140 Thru-bolt	M10x90 HST3	M10x90 ICCONS-FM753
	GREEN/YELLOW (4mm)		M12x140 Thru-bolt	M12x115 HST3	M12x110 ICCONS-FM753

 ZIP-CLIP SEISMIC RATED BRACE SCHEDULE C2 ANCHORS Brace Angle MAX 45°				
Brace Symbol	Zip-Clip Cable Type	HILTI Slab Connection	ICCONS Thru-bolt Slab Connection	ICCONS FM753 Slab Connection
	RED (2mm)	M10x90 HST3	M10x90 Thru-bolt	M10x90 ICCONS-FM753
	BLUE (3mm)	M10x90 HST3	M12x140 Thru-bolt	M10x90 ICCONS-FM753
	GREEN/YELLOW (4mm)	M12x115 HST3		

USING M12x110 ICCONS FM753 FOR A BLUE KIT REQUIRES A SEPARATE PURCHASE OF AN ANGLE BRACKET WITH A 13mm DIAMETER HOLE

C2 ANCHORS ARE USUALLY REQUIRED IN IMPORTANCE LEVEL 4 (IL4) BUILDINGS.

PLEASE CONTACT KUSCH FOR CLARIFICATION IF YOU ARE UNSURE WHETHER C1 OR C2 ANCHORS ARE REQUIRED. IF YOU WOULD LIKE TO USE AN ANCHOR NOT LISTED ABOVE, PLEASE CONTACT KUSCH AND WE CAN ASSESS THE ANCHOR TO DETERMINE IT'S SUITABILITY.

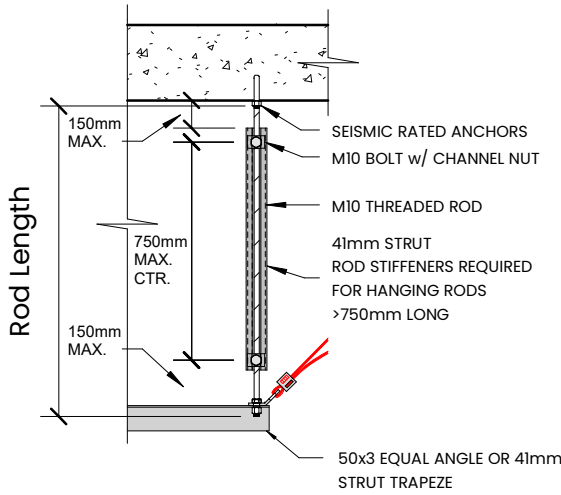

TYPICAL ROD STIFFENER
(USING 41mm STRUT)
NOTE: MUST BE USED IF
'ROD LENGTH' >750mm
U.N.O.

OR

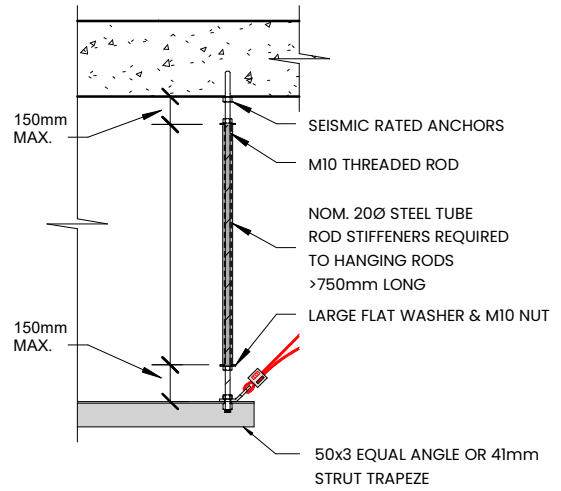

TYPICAL ROD STIFFENER
(USING 20NB CIRCULAR HOLLOW SECTION)
NOTE: MUST BE USED IF ROD LENGTH >750mm U.N.O.

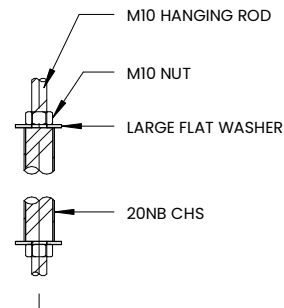
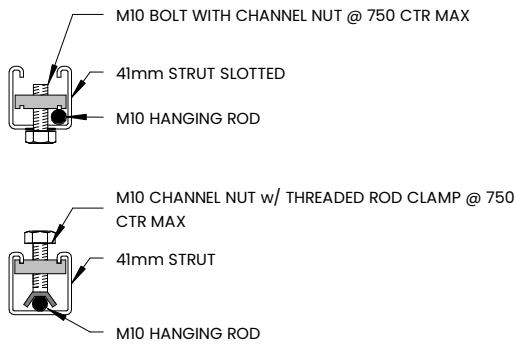

TYPICAL STRUT ROD STIFFENER CLAMPING METHODS

TWO-WAY CABLE BRACE

READ THESE INSTRUCTIONS IN CONJUNCTION WITH THE PLANS AND DETAILS ON PAGES 3-12 TO ACHIEVE OPTIMAL CAPACITY FROM CABLE.

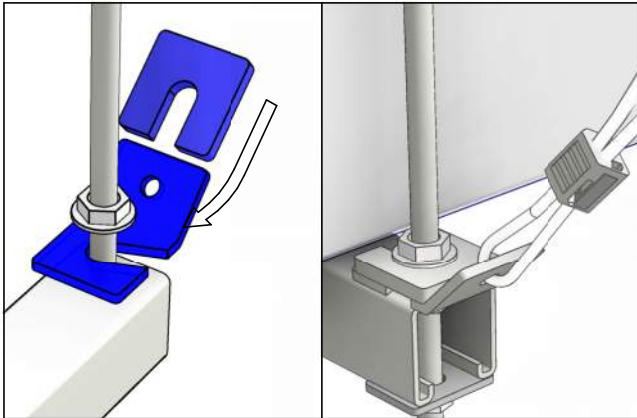
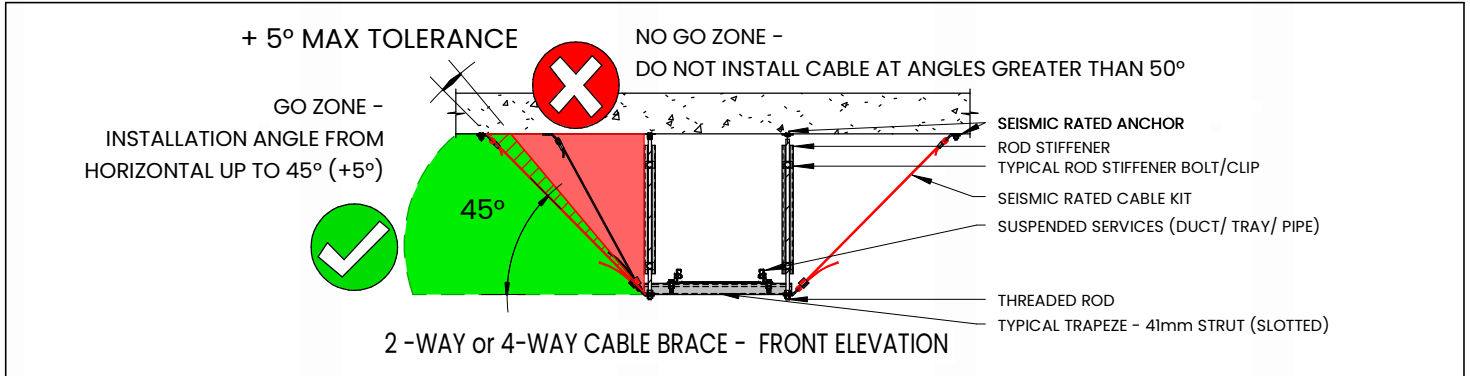

CABLE KIT BRACKET 'HOOKS' ONTO THREADED ROD. FIT SLOTTED SQUARE WASHER OVER THE CABLE BRACKET WITH EVERY KIT, IN THE ORIENTATION SHOWN.

TIGHTEN TOP LOCKING NUT AND THREAD CABLE THROUGH CABLE LOCK AND BRACKET. TIGHTEN CABLE AS PER KIT INSTRUCTIONS. STRUT WASHER AND LOCKING NUT UNDER 41mm TRAPEZE.

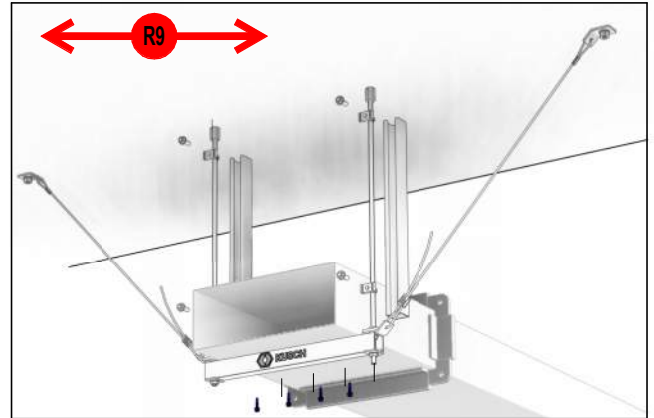

TYPICAL 2-WAY CABLE KIT TO TYPICAL TRAPEZE, SHOWN WITH ROD STIFFENERS BEING FITTED.

FIX DUCT TOP AND WITH 12g TEK SCREWS: QTY 4 MIN. SPACING @ 200mm MAX.

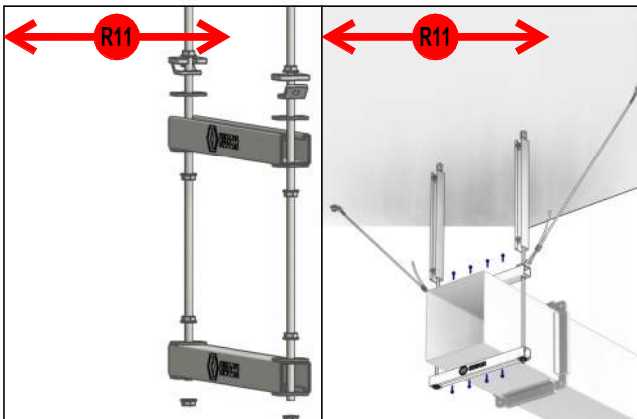

TOP TRAPEZE WITH M10 NUT AND STRUT WASHER TOP AND BOTTOM, CABLE KIT BRACKET AND SPACER. BOTTOM TRAPEZE WITH M10 NUT AND STRUT WASHER TOP & BOTTOM. FIX DUCT TOP AND BOTTOM WITH 12g TEK SCREWS: QTY 4 MIN. SPACING @ 200mm MAX.

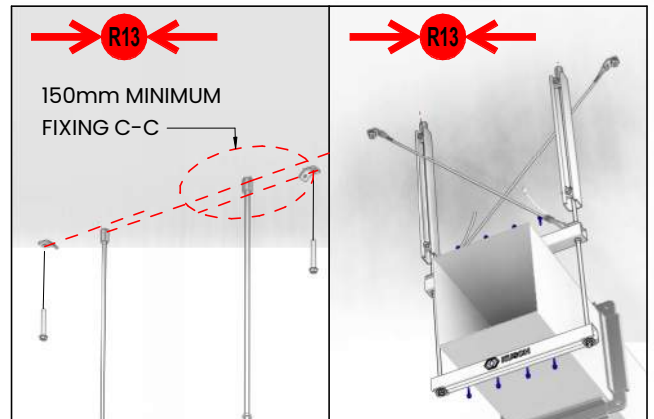

CABLE IN LINE WITH TRAPEZE - AS CLOSE AS PRACTICABLE, WHILE MAINTAINING MINIMUM 150mm BETWEEN SOFFIT FIXINGS.

TWO-WAY CABLE BRACE

READ THESE INSTRUCTIONS IN CONJUNCTION WITH THE PLANS AND DETAILS ON PAGES 3-12 TO ACHIEVE OPTIMAL CAPACITY FROM CABLE.



COLOURS DENOTE CABLE SPECIFIED BY SEISMIC DESIGN ENGINEER

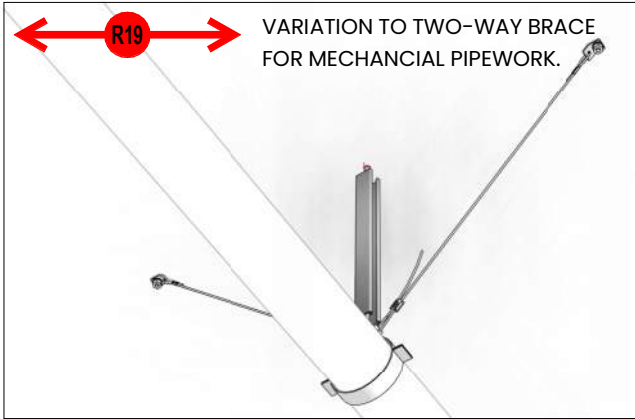

CABLE BRACKET LOCKED TO BTM OF THREADED ROD HANGER WITH M10 NUT WITH STRUT STIFFENER FITTED TO HANGER

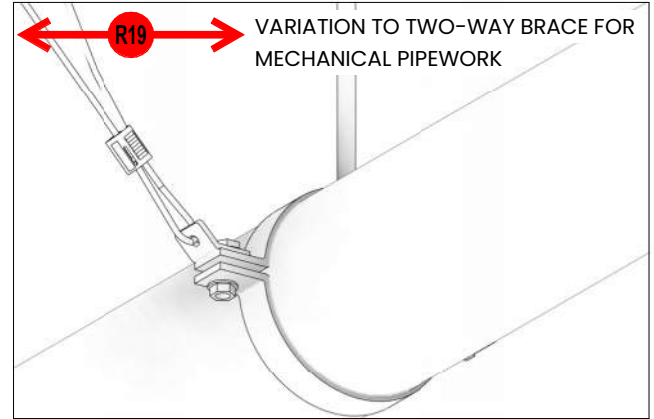

CABLE BRACKET FIXED TO PIPE CLAMP TAG.

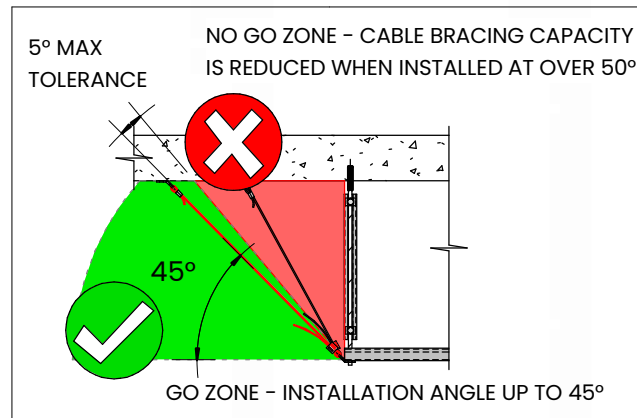

FOUR-WAY CABLE BRACE

READ THESE INSTRUCTIONS IN CONJUNCTION WITH THE PLANS AND DETAILS ON PAGES 3-12 TO ACHIEVE OPTIMAL CAPACITY FROM CABLE.

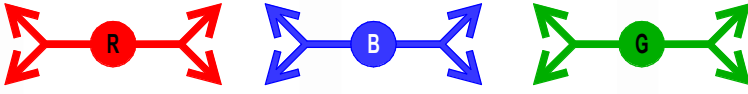

COLOURS DENOTE CABLE SPECIFIED BY SEISMIC DESIGN ENGINEER

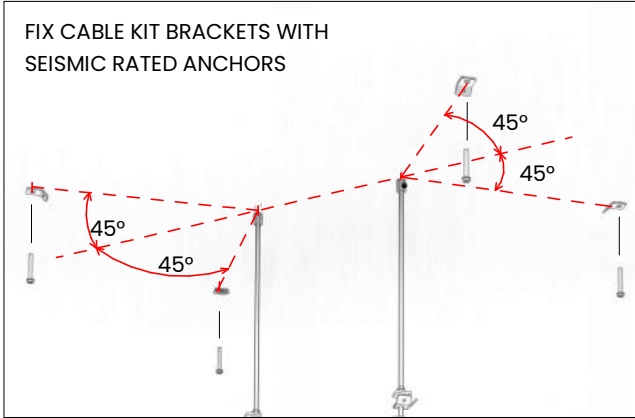

LAYOUT OF CABLE ANCHORS ON SOFFIT CRITICAL TO ACHIEVE DESIGN CAPACITY.

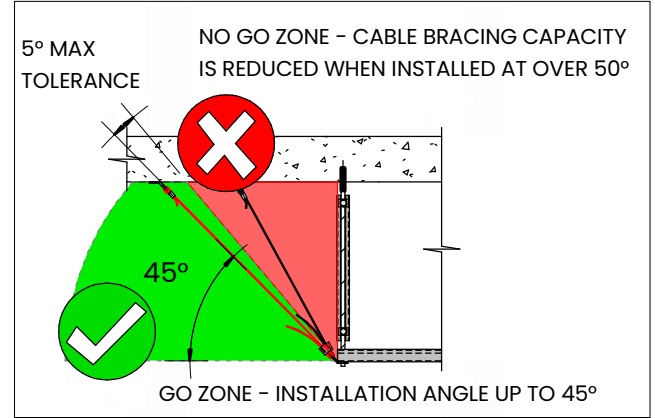

TYPICAL 4-WAY CABLE TRAPEZE SHOWN WITH ROD STIFFENERS

VARIATION WITH CABLES FIXED AT HANGER MID-LEVEL

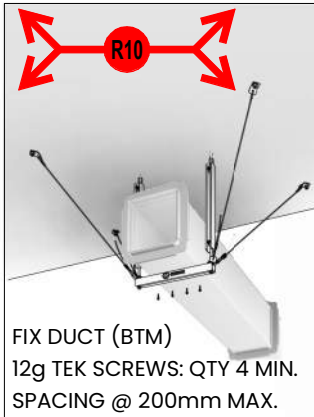

FIX DUCT (BTM)
12g TEK SCREWS: QTY 4 MIN.
SPACING @ 200mm MAX.

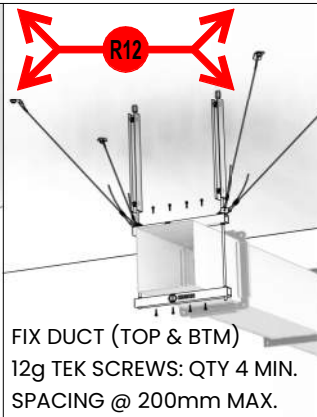

FIX DUCT (TOP & BTM)
12g TEK SCREWS: QTY 4 MIN.
SPACING @ 200mm MAX.

VARIATION WITH INTERNALLY ORIENTED CABLES FIXED TO MID-LEVEL TRAPEZE

VARIATION TO WITH INTERNALLY ORIENTED CABLES FIXED TO PIPES ON SHARED TRAPEZE

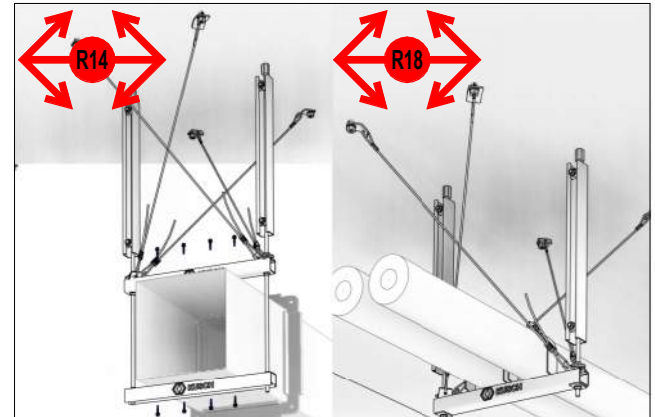

FIX DUCT (TOP & BTM)
12g TEK SCREWS: QTY 4 MIN.
SPACING @ 200mm MAX.

FIX PIPE USING TYPICAL FM132 PIPE CLAMPS TO TRAPEZE (41mm STRUT, OPEN UP)

TYPICAL 4-WAY CABLE, TRAPEZE FIXING TO ROD HANGER ARRANGEMENT (SHOWN INCLUDING HANGER MID-LEVEL TRAPEZE).

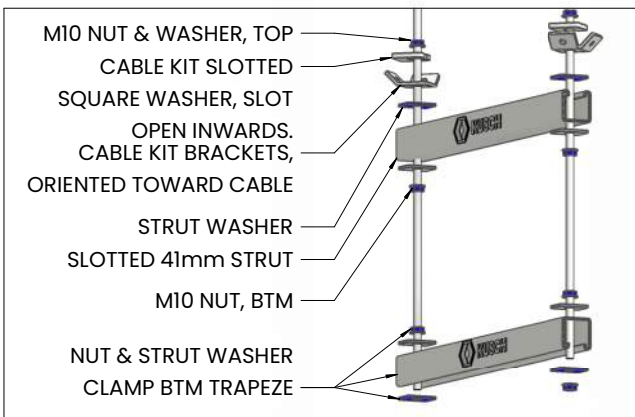

VARIATION TO WITH CABLES FIXED TO TAG OF PIPE CLAMP

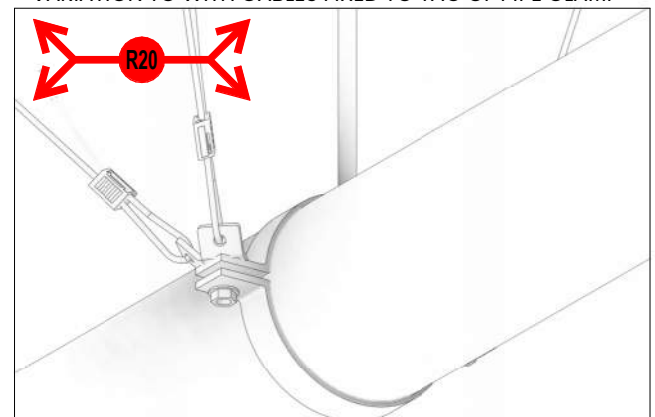

FOUR-WAY CABLE BRACE - SPLIT

READ THESE INSTRUCTIONS IN CONJUNCTION WITH THE PLANS AND DETAILS ON PAGES 3-12 TO ACHIEVE OPTIMAL CAPACITY FROM CABLE.

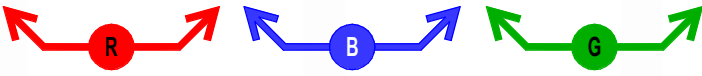

COLOURS DENOTE CABLE SPECIFIED BY SEISMIC DESIGN ENGINEER

TYPICALLY INSTALLED IN PAIRS TO PROVIDE LATERAL AND LONGITUDINAL RESTRAINT.

VARIATION TO TYPICAL FOUR-WAY CABLE BRACE - SPLITTING THE CABLES INTO TWO PAIRS TO HELP AVOID CLASH.

NOTE: SHOWN HERE AS TYPICAL TRAPEZE, MID-HEIGHT BACE OR MID-HEIGHT INTERNAL BRACE.

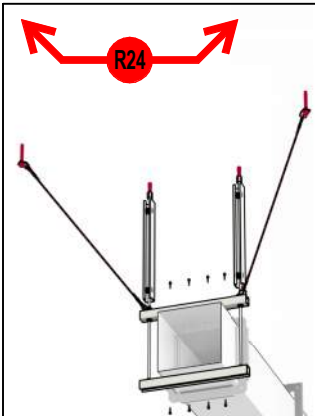
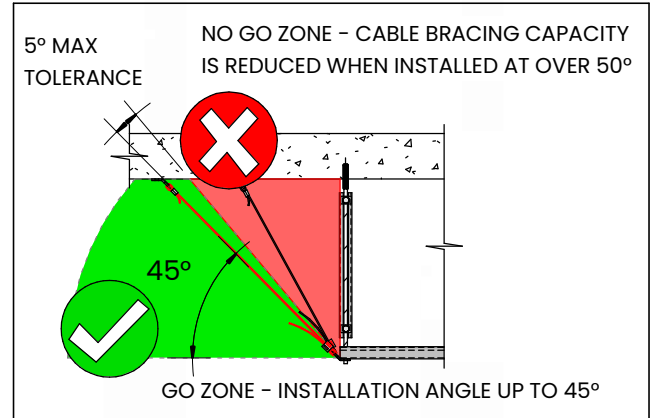
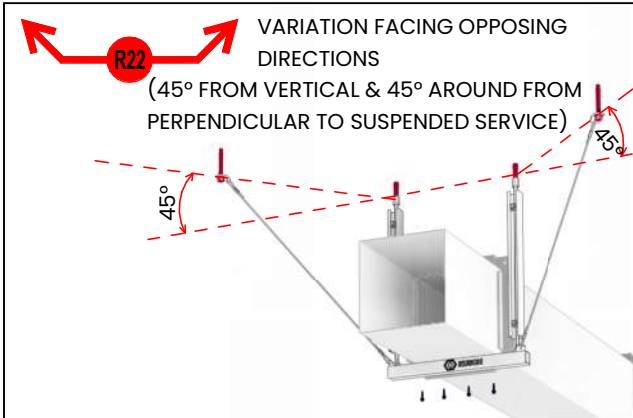

VARIATION FACING OPPOSING DIRECTIONS WITH CABLE TO MID-HANGER TRAPEZE.

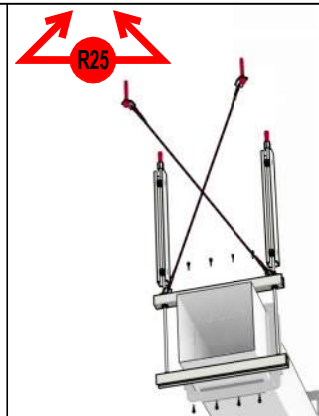

VARIATION FACING OPPOSING DIRECTIONS WITH INTERNALLY ORIENTED CABLE TO MID-HANGER TRAPEZE.

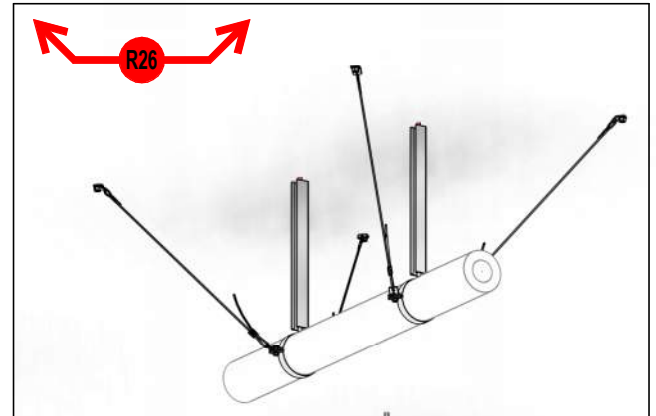

VARIATION TO 4WAY CABLE BRACE, TYPICALLY INSTALLED IN PAIRS FACING OPPOSING DIRECTIONS. ALLOWS FOR CLEARANCE TO ADJACENT SERVICES.

FIX DUCT (TOP & BTM) WITH 12g TEK SCREWS:
QTY 4 MIN. SPACING @ 200mm MAX.

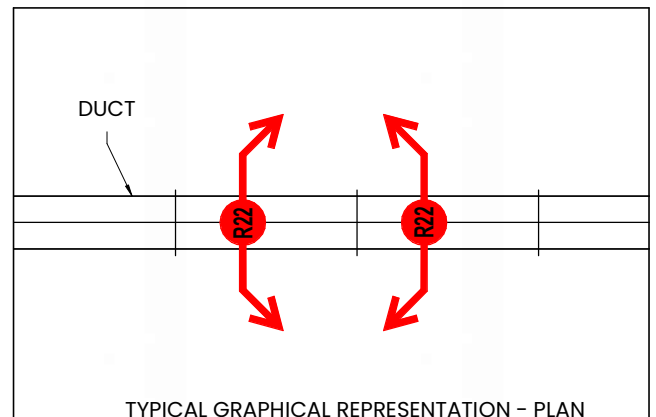

FOUR-WAY CABLE BRACE – SPLIT FCU & FAN

READ THESE INSTRUCTIONS IN CONJUNCTION WITH THE PLANS AND DETAILS ON PAGES 3-12 TO ACHIEVE OPTIMAL CAPACITY FROM CABLE.

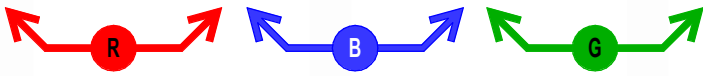

COLOURS DENOTE CABLE SPECIFIED BY SEISMIC DESIGN ENGINEER

INSTALLED IN PAIRS TO PROVIDE LATERAL AND LONGITUDINAL RESTRAINT.

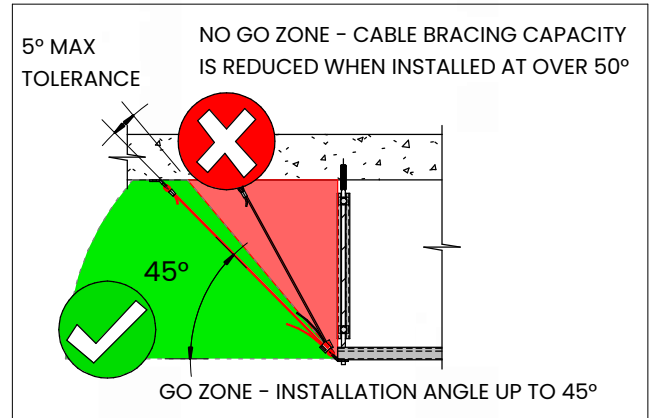
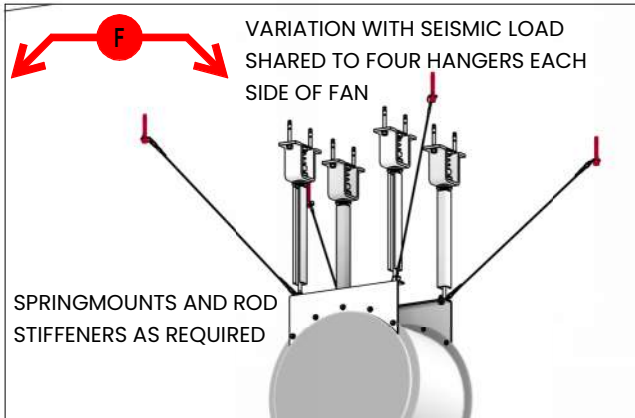

FIX CABLE KIT BRACKETS WITH M10 SEISMIC RATED ANCHORS AT REQUIRED SET OUT FROM SERVICE (45° FROM VERTICAL).

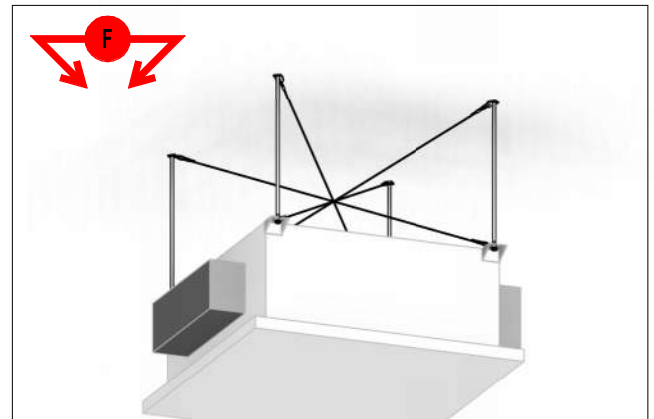
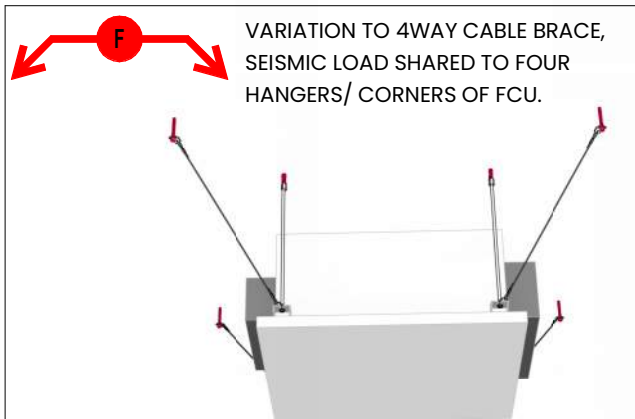

INTERNALLY ORIENTED CABLES CAN BE FIXED TO THE TOP OF THE THREADED ROD HANGER DIAGONALLY OPPOSITE PROVIDED THE ANGLE TO HORIZONTAL IS NOT GREATER THAN 45°. CABLE KIT BRACKETS REQUIRE LOCKING NUT AND LARGE WASHERS ABOVE AND BELOW ON THE THREADED ROD, POSITIONED AS CLOSE AS POSSIBLE TO THE SOFFIT.

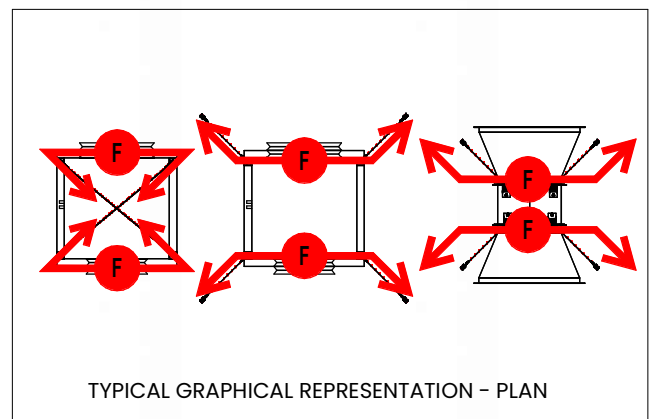

TYPICAL GRAPHICAL REPRESENTATION – PLAN

P4C - WALL FIXED STRUT WITH CABLE

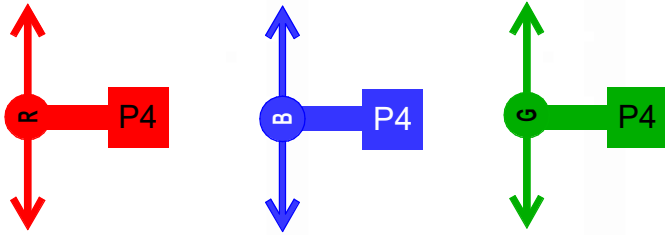

COLOURS DENOTE CABLE SPECIFIED BY KUSCH ENGINEER

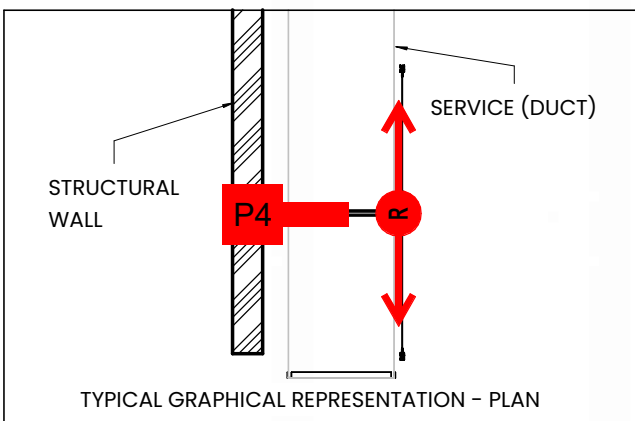
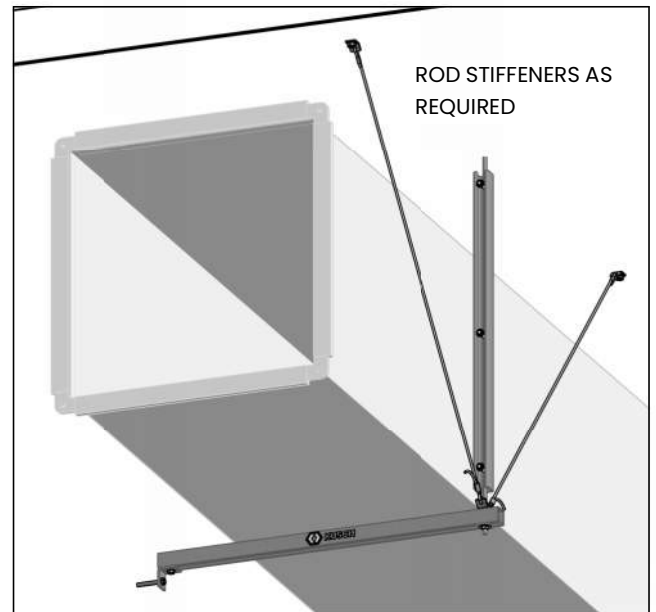
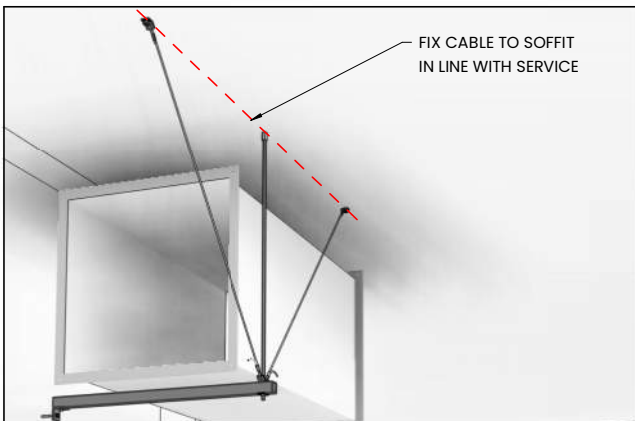
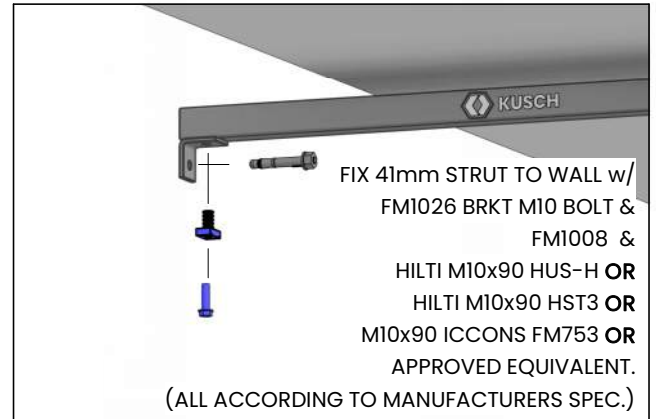
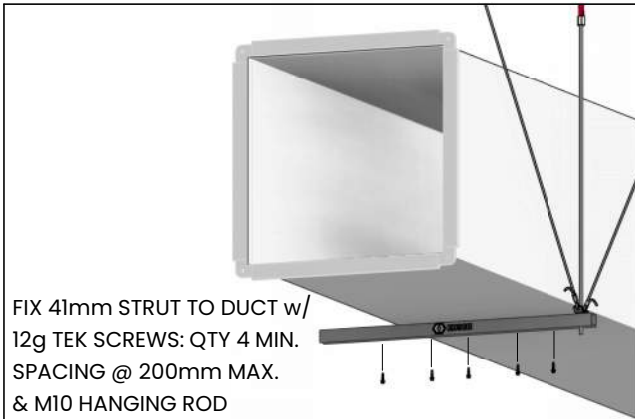

NOTE: P4C CAN BE APPLIED TO PIPE BY INVERTING STRUT AND USING TYPICAL PROPRIETARY FIXINGS AND CLAMPS. ALL ANCHOR FIXING 80mm MIN. DISTANCE TO CONCRETE EDGE.

K1 - SP50 CANTILEVER POST

NOTE: SUPA50 POSTS ARE AVAILABLE IN 1500, 1000 & 750mm LENGTHS.

K1 K1f

FIX 4- HILTI M10x90 HUS-H OR HILTI M10x90 HST3 OR M10x90 ICCONS FM753 OR APPROVED EQUIVALENT. ALL INSTALLED IN ACCORDANCE WITH MANUFACTURERS SPEC. 80mm MIN. EDGE DISTANCE. ANY OF THE FOLLOWING FIXING METHODS APPLY.

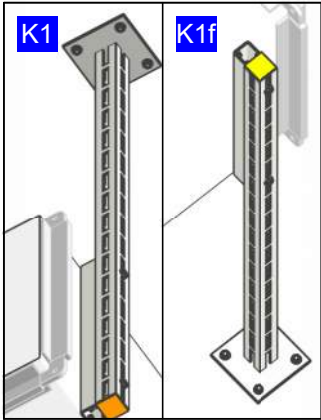

FLOOR FIXED POST OR SUSPENDED POST.
CUT POST HEIGHT TO SUIT & FIT SAFETY CAP.

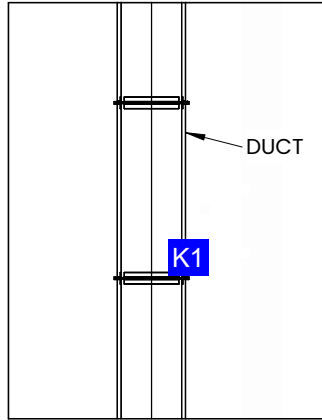

TYPICAL GRAPHICAL REPRESENTATION - PLAN

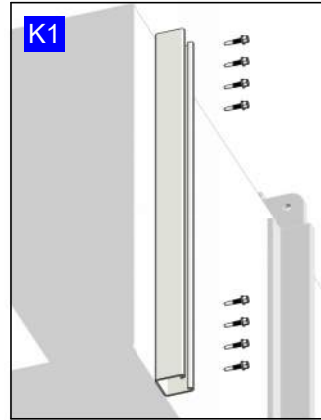

FIX 41mm STRUT TO DUCT WITH 12g TEK SCREWS: QTY 8 MIN. SPACING WITHIN TOP AND BOTTOM 100mm

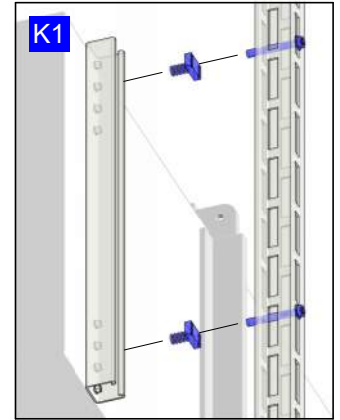

M10 BOLTS & FM1008 (THROUGH SUPA 50 POST) QTY: 2 MIN. 300mm MAX SPACING.

VARIATION, TO EXISTING HANGER, SP50-TRAPEZE CLAMP, RETRO-FIT OPTION

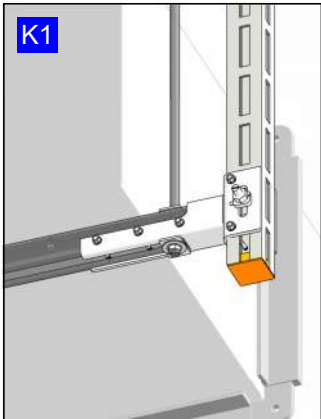

VARIATION, TO EXISTING HANGER, SP50-TRAPEZE CLAMP BOLTED TO K1 WITH 2-SPBOLT M10, 6-12G TEKSCREWS TO TRAPEZE, TRAPEZE FIXED TO DUCT WITH 12G TEK SCREWS, MIN. Qty 4, MAX CTS 200mm
LOCK TRAPEZE AND TRAPEZE CLAMP TO HANGIN ROD WITH LARGE SQUARE STRUT WASHERS TOP AND BOTTOM.

VARIATION, 50x3 SLOTTED EA ALLOWS TIGHTER CLEARANCE TO ADJACENT SERVICES.

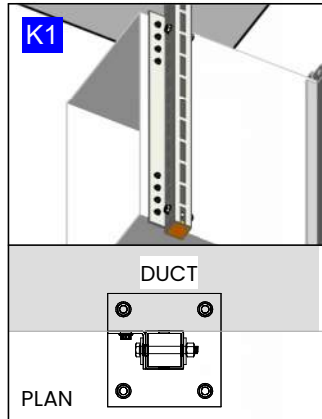

FIX 50x3 SLOTTED EA TO DUCT WITH 12g TEK SCREWS: QTY 8 MIN. SPACING WITHIN TOP AND BOTTOM 100mm

VARIATION, 3mm TOP HAT WITH MIN. 6-TEK SCREWS, TOP AND BOTTOM.

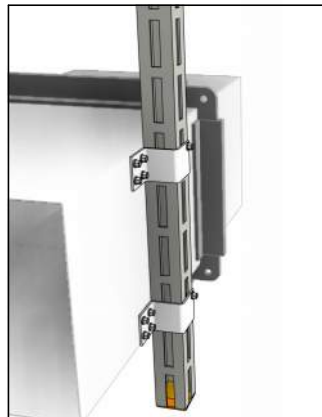

VARIATION, FM1026 WITH M10 BOLT TO TOP & BOTTOM OF DUCT.

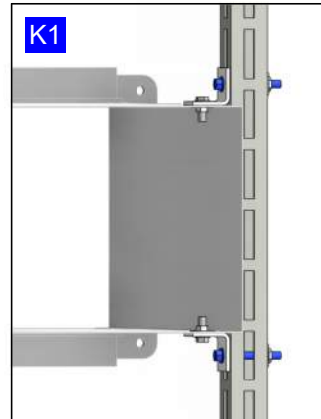

FIX FM1026 TO K1 WITH M10 THROUGH WITH LARGE SQUARE WASHERS.

VARIATION, 32x1.2 METAL STRAP WITH MIN. 4-12G TEK SCREWS TO TOP & BOTTOM OF DUCT.



ALTERNATIVELY, 'CYCLONE STRAP' FIXED THE SAME WAY

VARIATION, FM34HB10 TO TDF DUCT UNION AVOIDS DRILLING DUCT WALL.

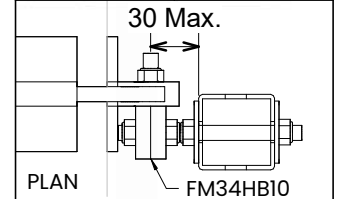
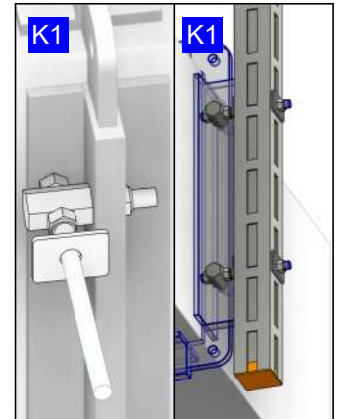

DRILL 12mm HOLES 100mm FROM EDGE OF DUCT & FIX 2-FM34HB10 WITH LOCKING NUT. THREADED ROD OR M10x120mm THROUGH SP50, LOCKED AS SHOWN WITH 2-LARGE FLAT WASHERS.

K1 – SP50 CANTILEVER POST

NOTE: SUPA50 POSTS ARE AVAILABLE IN 1500, 1000 & 750mm LENGTHS.

K1 K1f

FIX 4- HILTI M10x90 HUS-H OR HILTI M10x90 HST3 OR M10x90 ICCONS FM753 OR APPROVED EQUIVALENT. ALL INSTALLED IN ACCORDANCE WITH MANUFACTURERS SPEC. 80mm MIN. EDGE DISTANCE.

VARIATION, 41mm STRUT TELESCOPING FROM SP50.



FIX 41mm STRUT TO SP50 WITH MIN. 2-M12 BOLTS & FM1010 MIN 300 CTS WITH STRUT WASHERS.

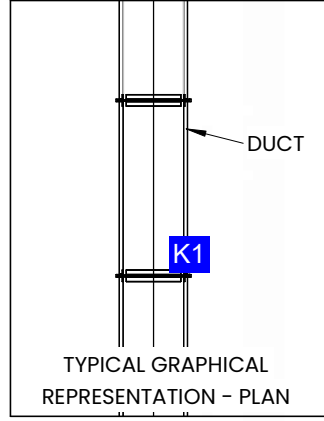

TYPICAL GRAPHICAL REPRESENTATION – PLAN

VARIATION TO MECHANICAL EQUIPMENT (FCU).

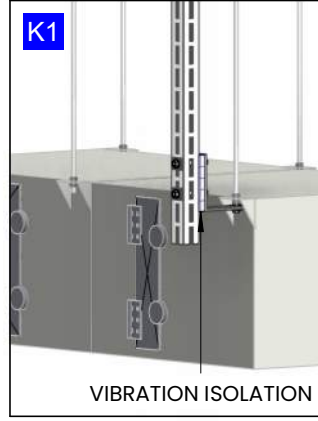

SP50-1325 BRACKET TO K1 WITH VIBRATION ISOLATION AND 2-M10 BOLTS THROUGH. LOCKED TO FCU WITH NUTS TOP AND BTM TO HANGING ROD.

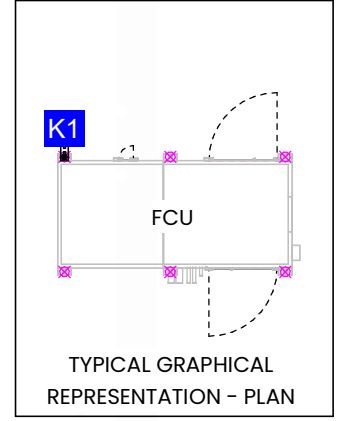

TYPICAL GRAPHICAL REPRESENTATION – PLAN

VARIATIONS TO MECHANICAL PIPEWORK. (TIMBER FERRULE AS REQUIRED)

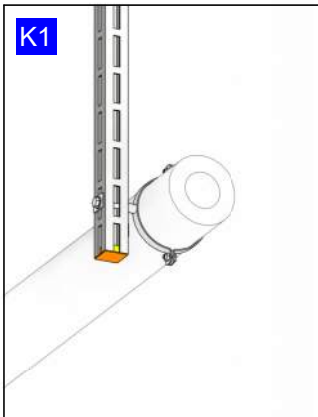

NUT CLAMP AND STRUT WASHER.

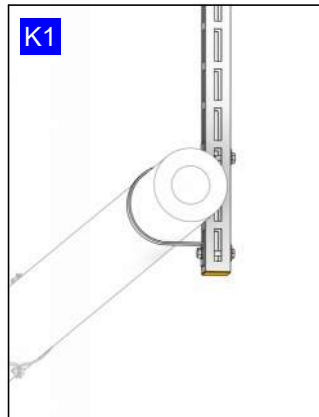

SADDLE CLAMP WITH 2-M10 BOLTS & STRUT WASHERS.

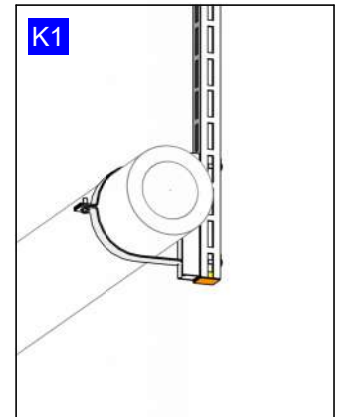

FM132 CLAMP WITH 41mm STRUT, 2-M10 BOLTS AND STRUT WASHERS.

K1 - SP50 POST WITH STRUT TRAPEZE

K1

NOTE: SUPA50 POSTS ARE AVAILABLE IN 1500, 1000 & 750mm LENGTHS.

FIX 41mm STRUT TO DUCT WITH 12g TEK SCREWS: QTY 4 MIN.
200mm MAX. CTS

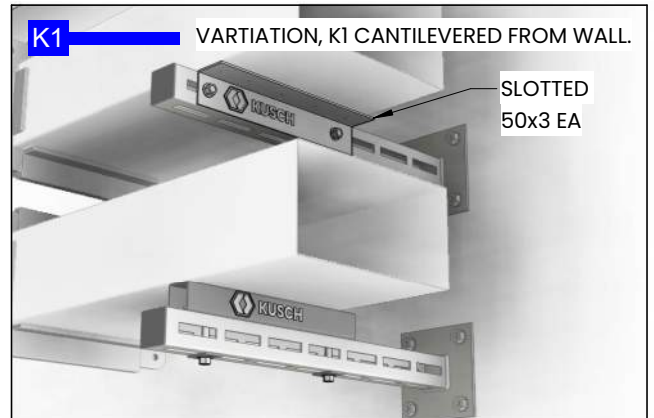
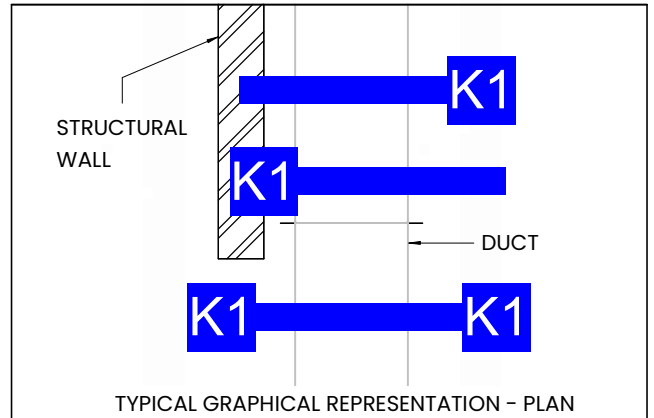
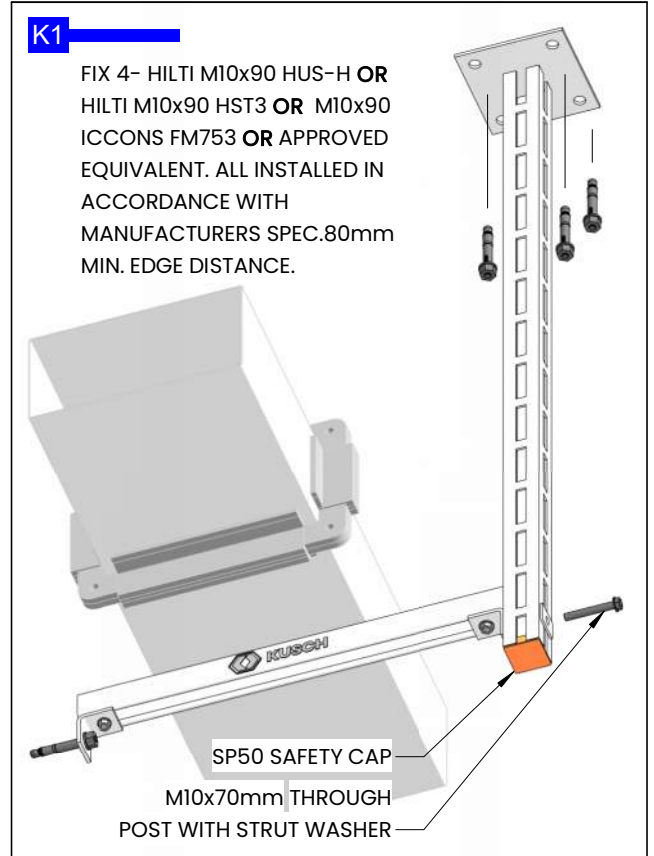
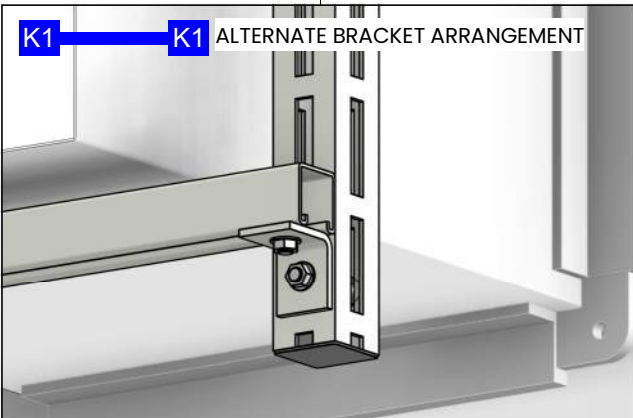
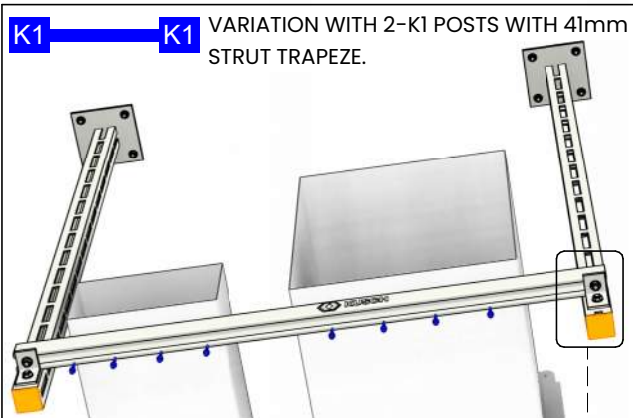
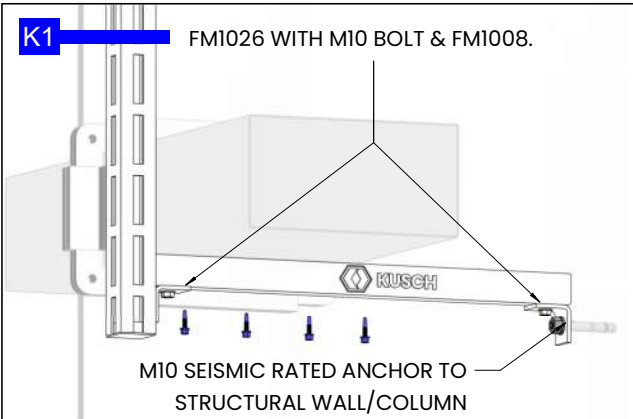
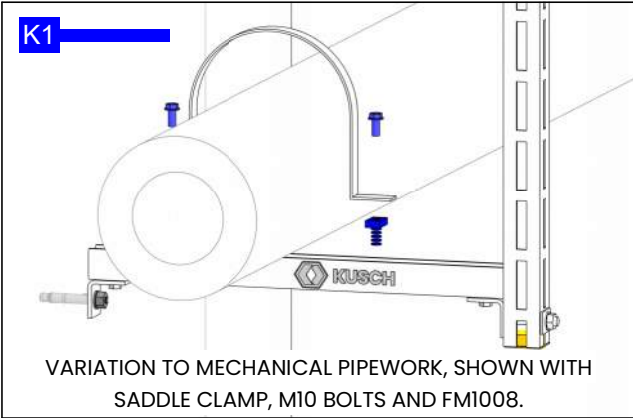

C2 & C3 - CANTILEVER STRUT POST

C2

C3

WELDED BASEPLATE BOLTED BASEPLATE

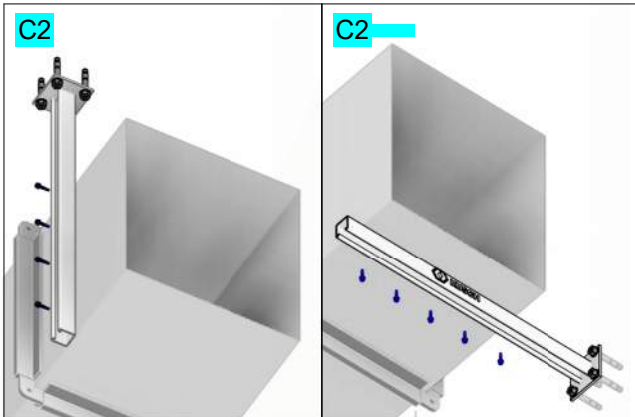

FIX DUCT WITH 12g TEK SCREWS: QTY 4 MIN. SPACING @ 200mm MAX. FIX FM2073 WELDED 41mm STRUT w/ HILTI M10x90 HUS-H OR HILTI M10x90 HST3 OR M10x90 ICCONS FM753 OR APPROVED EQUIVALENT. ALL INSTALLED IN ACCORDANCE WITH MANUFACTURERS SPEC. 80mm MIN. EDGE DISTANCE. NOTE: FM2073 (L) LENGTHS ARE MADE TO ORDER.

C3 VARIATION WITH BOLTED BASEPLATE

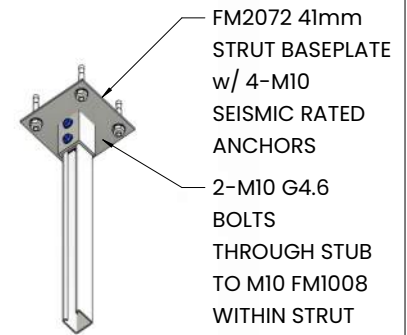

C2 VARIATION FIXING TO MECHANICAL PIPEWORK

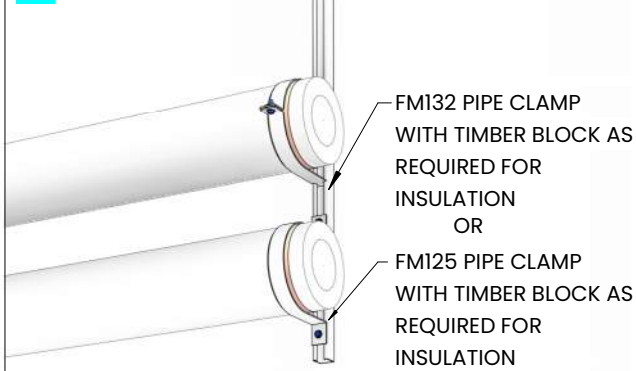

C2 VARIATION FIXING TO DUCT UNION

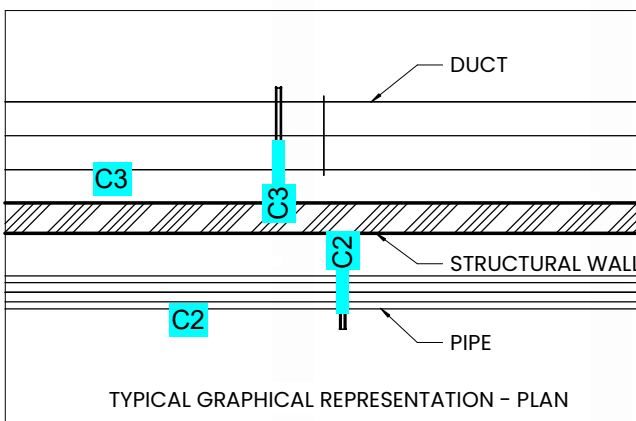
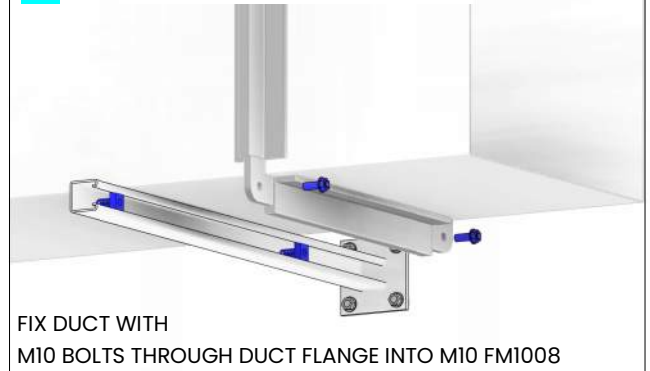

C2 VARIATION TO PIPE

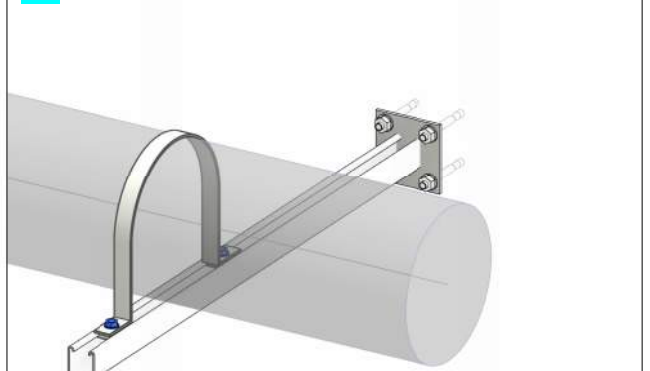

NOTE: C2 AND C3

SP50, SP80 & SP100 POSTS

SOFFIT-FIXED	J1	FLOOR-FIXED	H1	FLOOR-SOFFIT	G1	SUPA 50	M10 SPBOLTS WITH M12 ANCHORS
	J2		H2		G2	SUPA 80	M12 SPBOLTS WITH M16 ANCHORS
	J3		H3		G3	SUPA 100	M12 SPBOLTS WITH M16 ANCHORS

FOR DETAILS ON FIXING TO SERVICES, SEE Pg 19
 FOR SP80 & SP100: - USE M12 FIXINGS FOR STRUT METHOD
 - TEK SCREW TO POST FOR EA METHOD

INSTALLATION DETAILS ON THIS PAGE CAN BE APPLIED TO **ALL SUPA SIZES** BY CHANGING BASEPLATE AND BOLT SIZE.

J1
H1

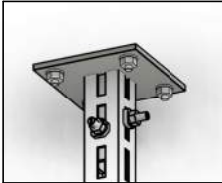

FIX SP50-2072 BASEPLATE TO SUPA WITH 2-SPBOLT-M10S. FIX BASEPLATE TO SOFFIT WITH 4-M12 HILTI HST3, ICCONS FM753 OR APPROVED EQUIVALENT SEISMIC RATED ANCHORS

J2 J3
H2 H3

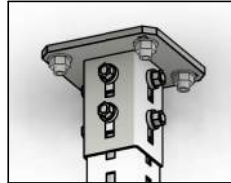

FIX SP80 OR SP100-2072 BASEPLATE TO SUPA WITH 6-SPBOLT-M12S. FIX BASEPLATE TO SOFFIT WITH 4-M16 HILTI HST3, ICCONS FM753 OR APPROVED EQUIVALENT SEISMIC RATED ANCHORS

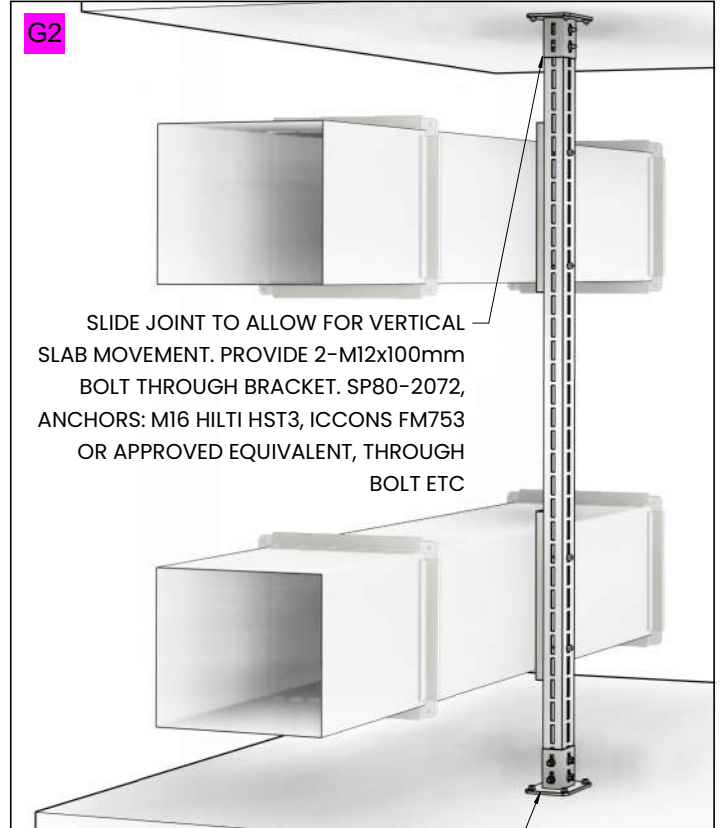

SLIDE JOINT TO ALLOW FOR VERTICAL SLAB MOVEMENT. PROVIDE 2-M12x100mm BOLT THROUGH BRACKET. SP80-2072, ANCHORS: M16 HILTI HST3, ICCONS FM753 OR APPROVED EQUIVALENT, THROUGH BOLT ETC

STANDARD SP80 BASEPLATE CONNECTION AS PER DETAIL AT TOP OF PAGE (NO SLIDE JOINT REQUIRED)

HURDLE VARIATION TO G3 POST

G3 G3
G2 G2

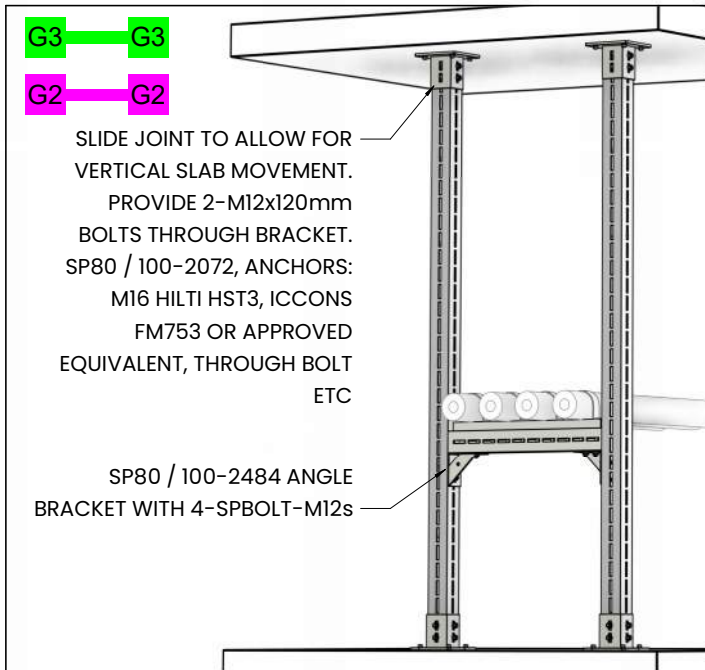

SLIDE JOINT TO ALLOW FOR VERTICAL SLAB MOVEMENT. PROVIDE 2-M12x120mm BOLTS THROUGH BRACKET. SP80 / 100-2072, ANCHORS: M16 HILTI HST3, ICCONS FM753 OR APPROVED EQUIVALENT, THROUGH BOLT ETC

SP80 / 100-2484 ANGLE BRACKET WITH 4-SPBOLT-M12s

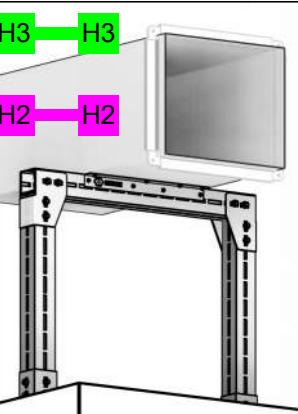

H3 H3
H2 H2

VARIATION TO H2 / H3 POST, WITH 2-SP80 / 100 -156 SHOE BRACKETS EACH WITH 8-SPBOLT-M12S. FIX DUCT TO HURDLE WITH EITHER 41mm STRUT OR 50x3 EQUAL ANGLE. (BOTH WITH 12G TEK SCEWS, MIN Qty 4, MAX. CTS 200mm)

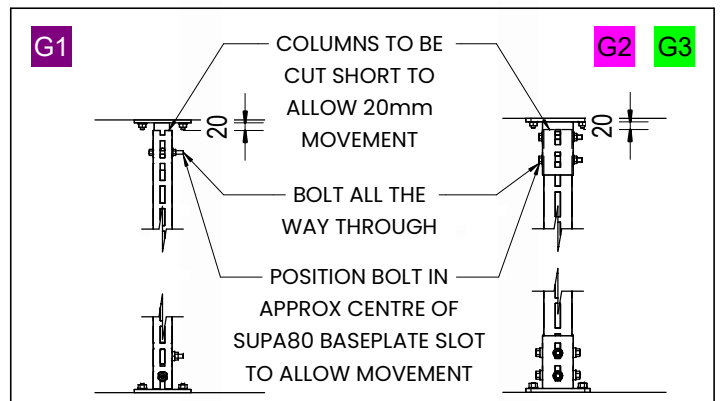

COLUMNS TO BE CUT SHORT TO ALLOW 20mm MOVEMENT
 BOLT ALL THE WAY THROUGH
 POSITION BOLT IN APPROX CENTRE OF SUPA80 BASEPLATE SLOT TO ALLOW MOVEMENT

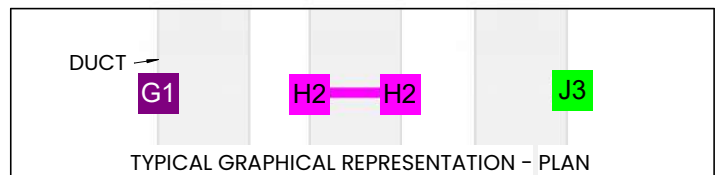

TYPICAL GRAPHICAL REPRESENTATION - PLAN

P1,3,4 & 4T - WALL FIXED STRUT BRACES

P1 P3 P4

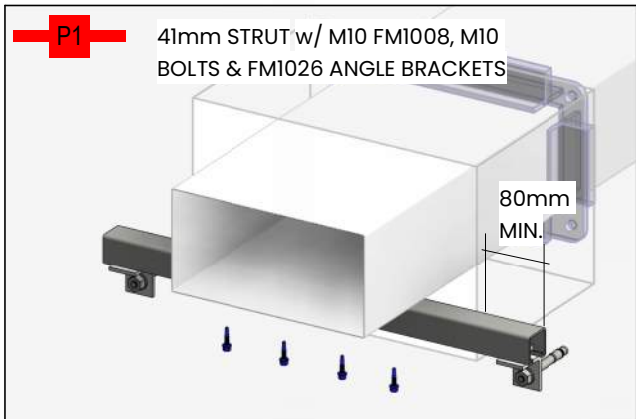

P1 41mm STRUT w/ M10 FM1008, M10 BOLTS & FM1026 ANGLE BRACKETS

80mm MIN.

FIX DUCT WITH 12g TEK SCREWS: QTY 4 MIN. SPACING @ 200mm MAX.

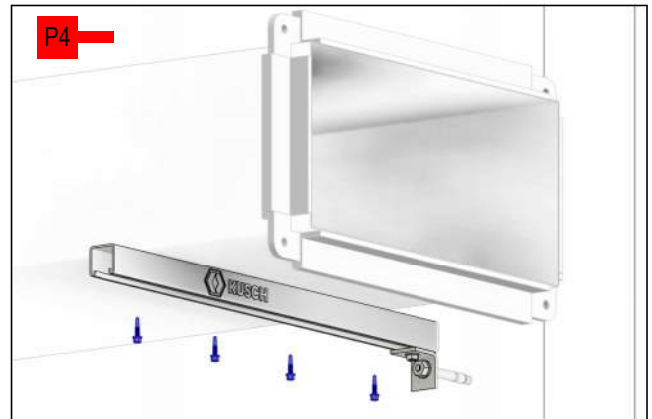

P4

FIX DUCT WITH 12g TEK SCREWS: QTY 4 MIN. SPACING @ 200mm MAX.

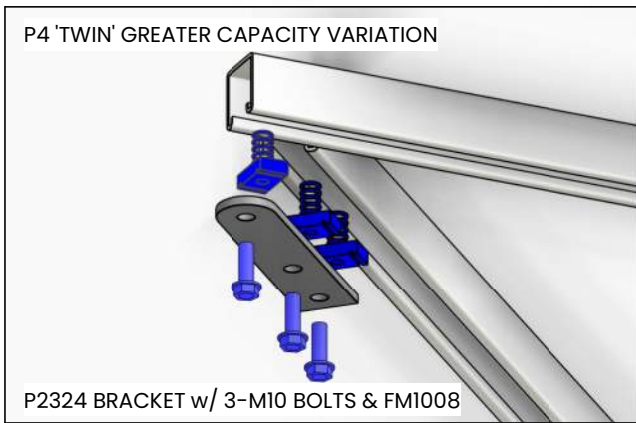

P4 'TWIN' GREATER CAPACITY VARIATION

P2324 BRACKET w/ 3-M10 BOLTS & FM1008

FIX DUCT WITH 12g TEK SCREWS: QTY 4 MIN. SPACING @ 200mm MAX.



P4

P4

FIX TO: CONCRETE / CORE-FILLED BLOCK WALL WITH HILTI M10x90 HUS-H OR HILTI M10x90 HST3 OR M10x90 ICCONS FM753 OR APPROVED EQUIVALENT. (ALL ACCORDING TO MANUFACTURERS SPEC.)
FIX TO: STEEL FRAME w/ 14g TEK SCREWS;
TIMBER FRAME w/ M10 COACH BOLTS

VARIATION OF P1, TO STUD WALL.

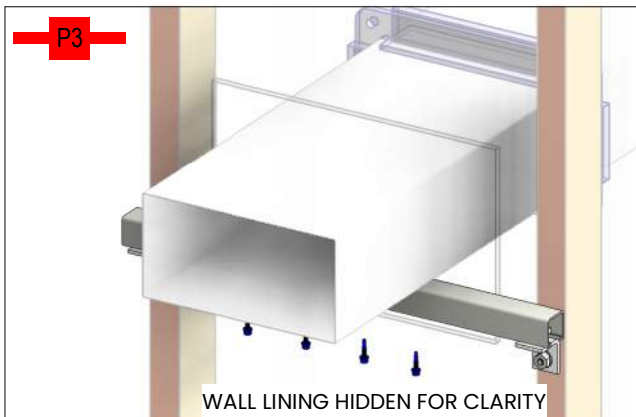

P3

WALL LINING HIDDEN FOR CLARITY

FIX DUCT WITH 12g TEK SCREWS: QTY 4 MIN. SPACING @ 200mm MAX.

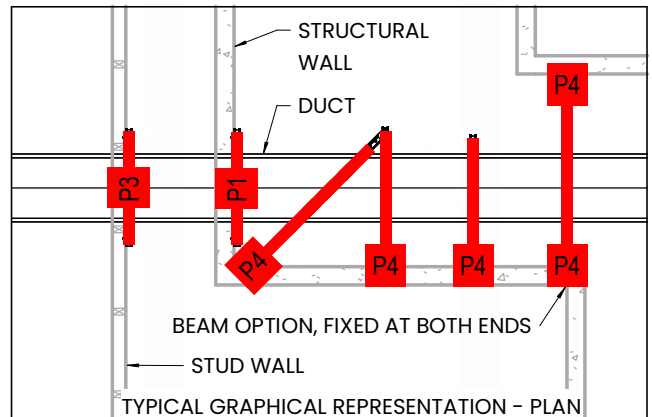

STRUCTURAL WALL

DUCT

BEAM OPTION, FIXED AT BOTH ENDS

STUD WALL

TYPICAL GRAPHICAL REPRESENTATION - PLAN

P6, 9 & 9C - STRUT BRACES

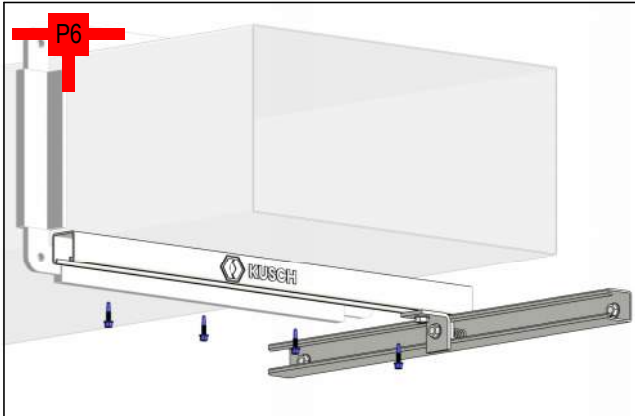

FIX DUCT w/ 12g TEK SCREWS: QTY 4 MIN. SPACING @ 200mm MAX. FIX FM1026 ANGLE BRACKET TO STRUT w/ 2-M12 BOLT & FM1008.

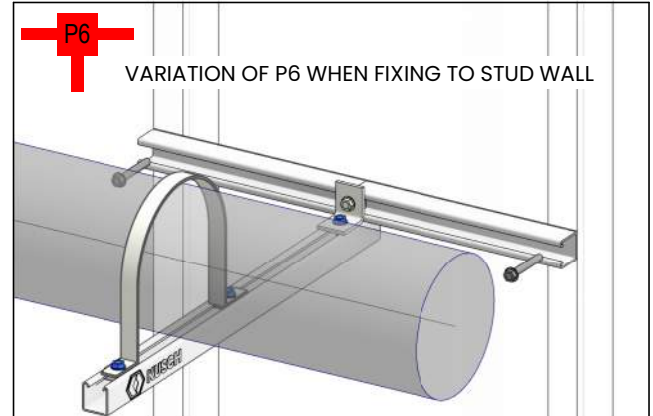

VARIATION OF P6 WHEN FIXING TO STUD WALL
STEEL FRAME - 14g TEK SCREWS
TIMBER FRAME - M10 COACH BOLTS

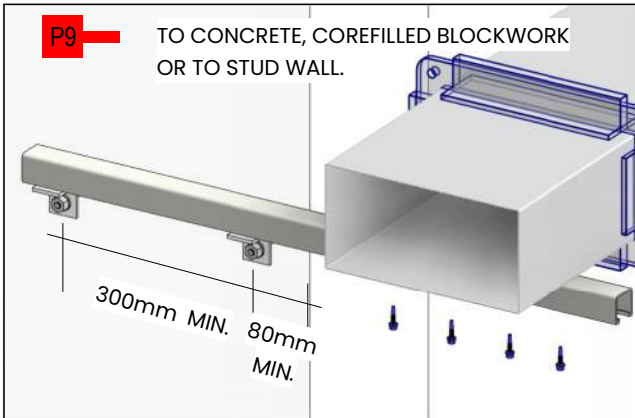

P9 TO CONCRETE, COREFILLED BLOCKWORK OR TO STUD WALL.
300mm MIN. 80mm MIN.

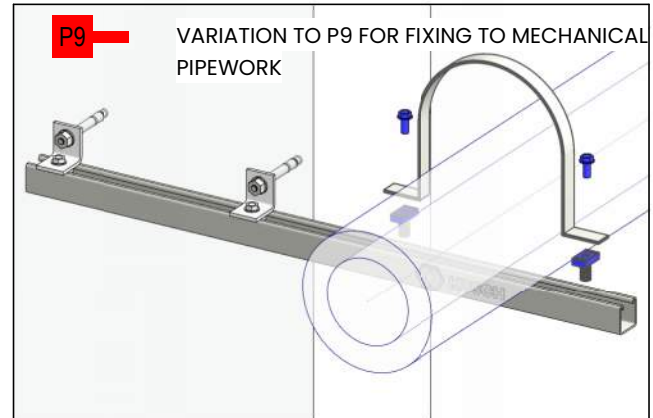

VARIATION TO P9 FOR FIXING TO MECHANICAL PIPEWORK
FIX PIPE w/ TYPICAL SADDLE CLAMP, M12 BOLTS & FM1008

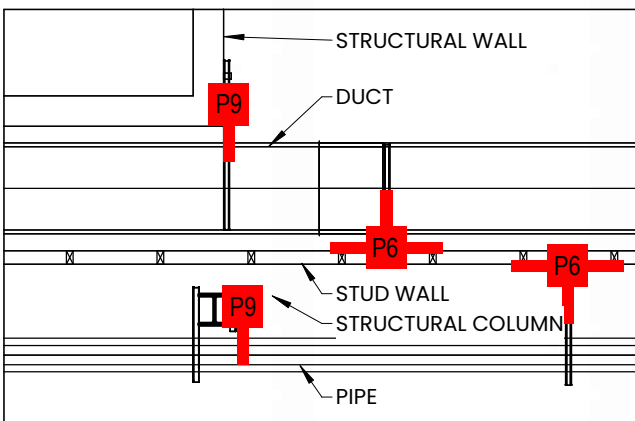

TYPICAL GRAPHICAL REPRESENTATION - PLAN

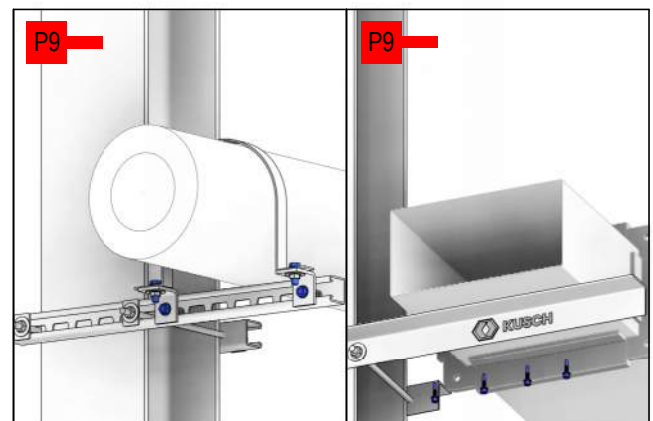

VARIATION OF P9 TO STRUCTURAL COLUMN WITH SLOTTED STRUT
VARIATION OF P9 TO STRUCTURAL COLUMN WITH SLOTTED 50x3 EA

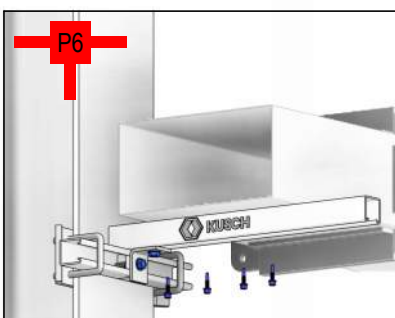

VARIATION OF P6, TO STRUCTURAL COLUMN WITH 2-FM174 CLAMPS

P8 - STRUT BRACE TO SOFFIT

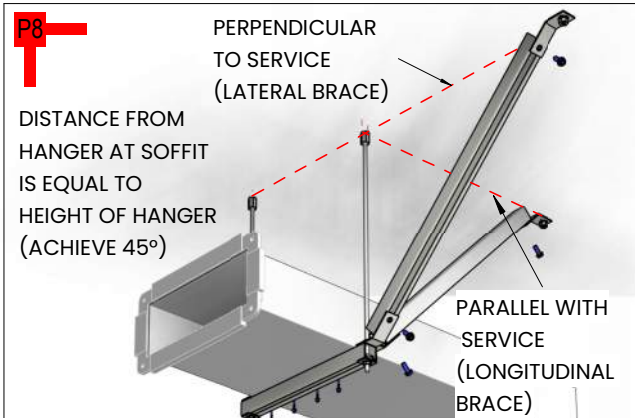

FMI546 BRACKETS TO SOFFIT TO THIS LAYOUT WITH HILTI M10x90 HUS-H OR HILTI M10x90 HST3 OR M10x90 ICCONS FM753 OR APPROVED EQUIVALENT. ALL INSTALLED IN ACCORDANCE WITH MANUFACTURERS SPEC.80mm MIN. EDGE DISTANCE.

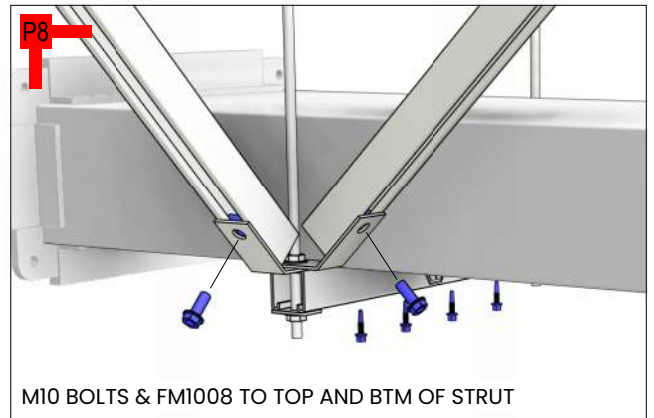
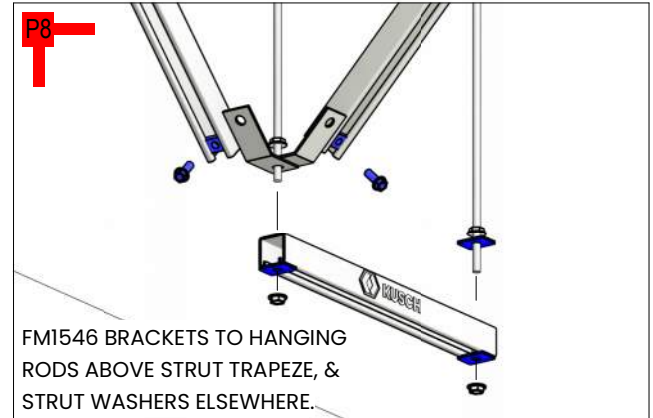

M10 BOLTS & FMI1008 TO TOP AND BTM OF STRUT

FIX DUCT: 12g TEK SCREWS: QTY 4 MIN. SPACING @ 200mm MAX.

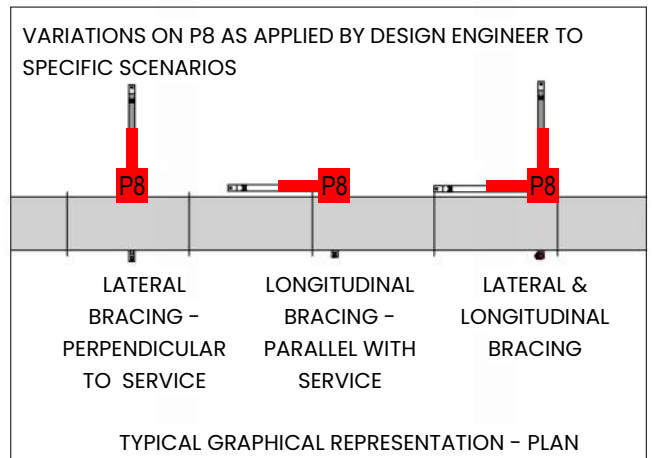

S50 - WALL FIXED SP50 WITH CABLE

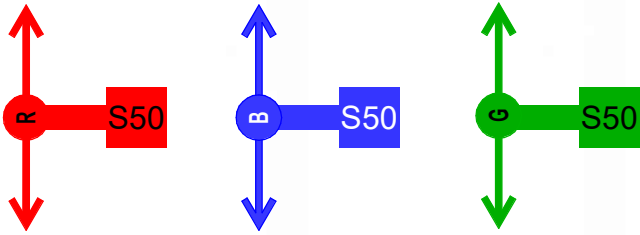

COLOURS DENOTE CABLE SPECIFIED BY SEISMIC DESIGN ENGINEER

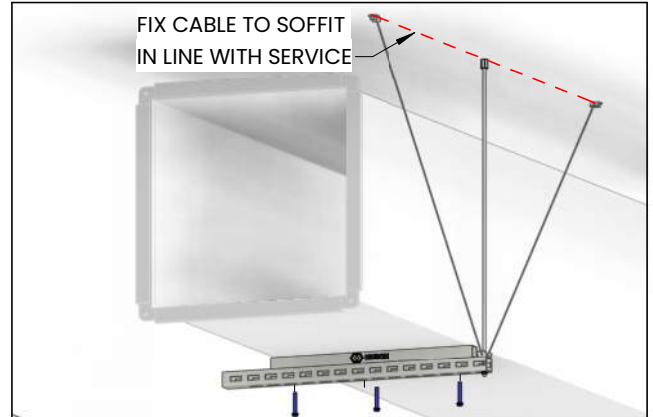

FIX SP50 TO HANGER WITH M10 NUT & LARGE WASHERS. FIX SP50 TO STRUT WITH M10x70mm TO FM1008. USE LARGE FLAT WASHERS TO M10 BOLTS.

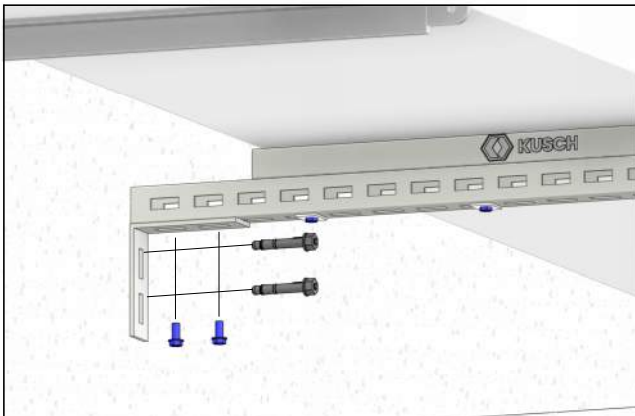

SP1325 ANGLE BRACKET TO WALL w/ 2-SPBOLTS M12S & HILTI M12x105 HST3 OR M10x110 ICCONS FM753 OR APPROVED EQUIVALENT. ALL INSTALLED IN ACCORDANCE WITH MANUFACTURERS SPEC.



NOTE: S50 CAN BE APPLIED TO PIPE BY DELETING 41MM STRUT & USING TYPICAL PROPRIETARY FIXINGS AND CLAMPS DIRECTLY TO SP50. ALL ANCHOR FIXING 80mm MIN. DISTANCE TO CONCRETE EDGE.

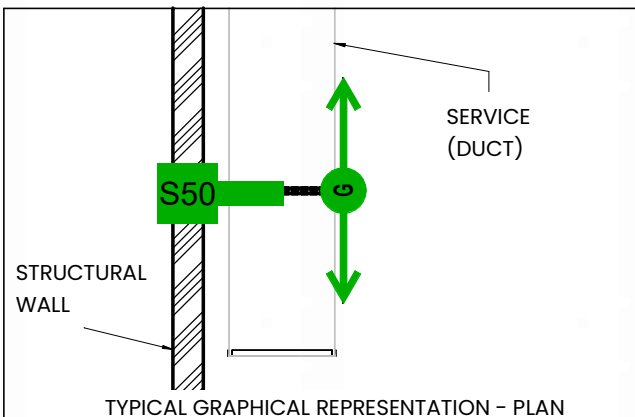

FLOOR MOUNTED MECHANICAL EQUIPMENT

TYPE AND SIZE OF FIXINGS FOR FLOOR MOUNTED PLANT VARY DEPENDING ON DIMENSIONS AND WEIGHT OF THE EQUIPMENT. FIXING DESIGN WILL BE ON A CASE-BY-CASE BASIS. TALK TO YOU KUSCH ENGINEER FOR DETAILS / DESIGN.

IN ALL CASES, USE SEISMIC RATED ANCHORS AND ENSURE THERE IS 80mm MINIMUM EDGE DISTANCE. USE SPRING MOUNTS AS REQUIRED.

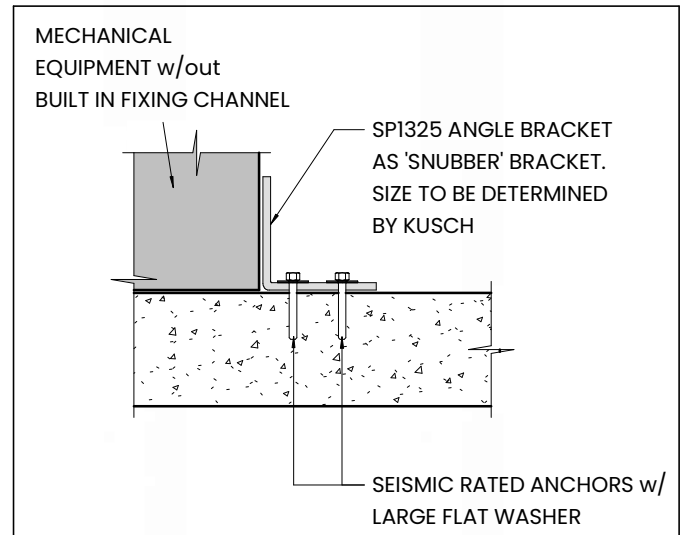
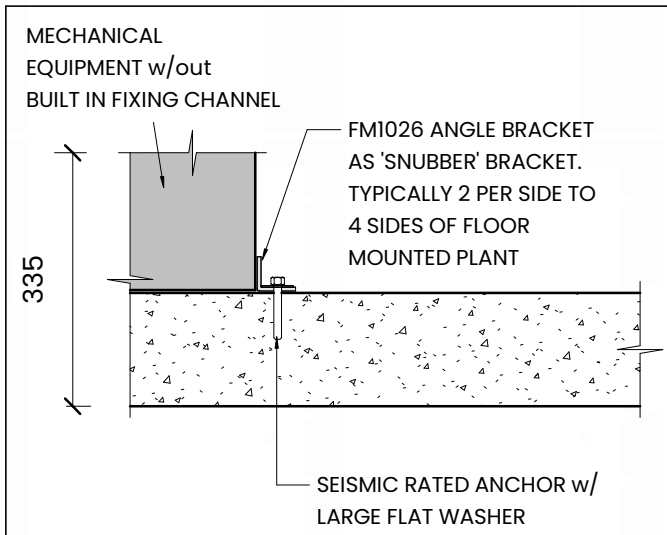
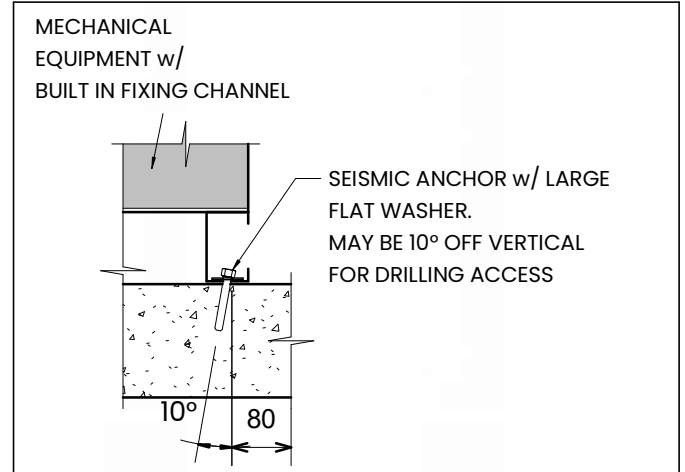
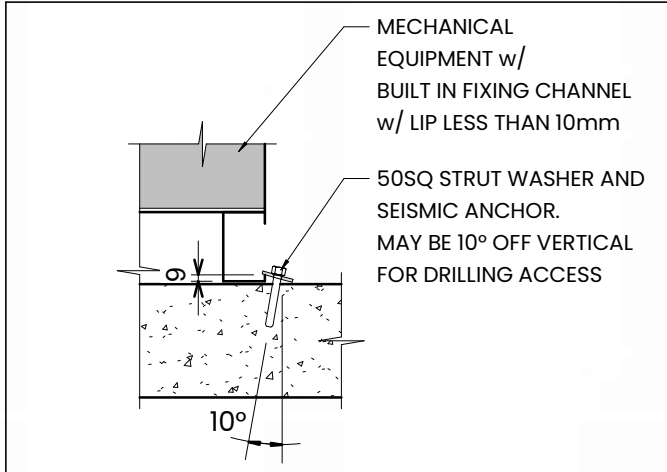

2-SP80*1325 ANGLE BRACKETS PER SIDE w/ 2-M12 SEISMIC ANCHORS EA. TO THIS 12.5 TONNE CONDENSING UNIT.

MINIMUM 80mm FIXING TO EDGE OF PLINTH

