

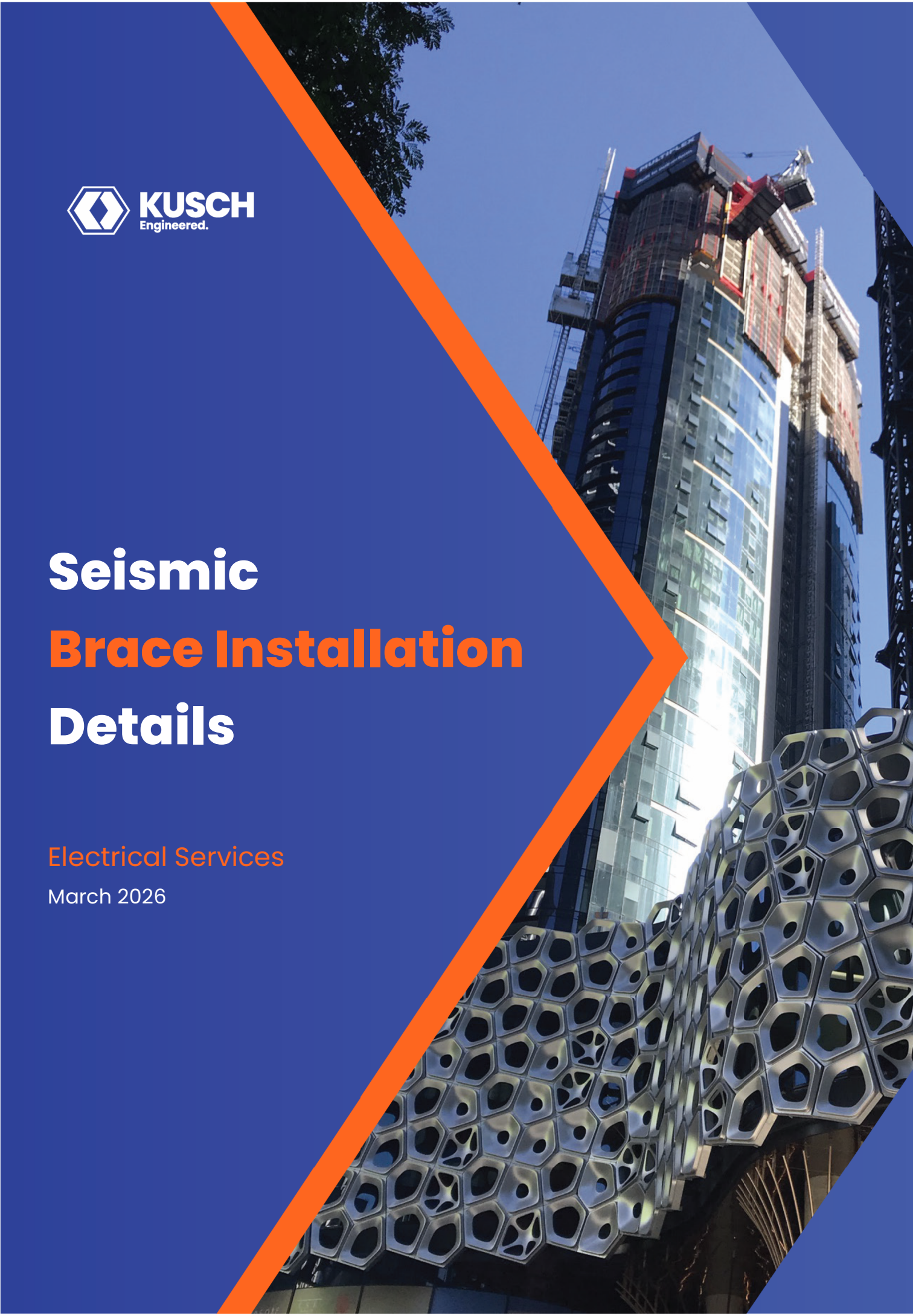

Seismic Brace Installation Details

Electrical Services

March 2026



KUSCH engineers project-specific seismic solutions that minimise material use, reduce labour, and actually work when you're on site. Every solution is designed for compliance with AS1170.4 and AS5216, while reducing construction complexity. We support your team from concept to install - solving seismic, structural and buildability challenges directly on site. We design mechanical, electrical, fire, and hydraulic services, along with other non-structural elements.

We Deliver:



Brace-Free Seismic Solutions

KUSCH uses dynamic analysis to calculate how far your services will swing in an earthquake. This allows us to reduce the amount of bracing required on site - saving time, labour, and materials.



Braced Seismic Solutions

KUSCH designs efficient, code-compliant braced seismic systems tailored to your service layout. Our approach ensures optimal bracing placement while reducing unnecessary materials, installation time, and on-site complexity.



Services Support Design

We provide seismic and structural design of supports and fixings including:

- Concrete anchors to AS5216
- Shallow embedment requirements
- Anchoring to hollowcore, blockwork or timber
- Anchor schedules and fixing registers
- C1 & C2 seismic anchors
- Fire-rated service supports
- Supply of Seismic Bracing Materials
- Additional Structural Loads Mandated by the NCC: Wind, Thermal & Building Movement



BIM-Integrated Seismic Coordination

Our seismic designs are fully modelled in Revit, delivering:

- Clash-free layouts
- Nested bill of materials with cut lengths
- Unique brace tags for QA
- Trimble points for precise pre-drilled anchor placement

This document sets out the desired installation methodology for our most common brace solutions.

1. TYPICAL INSTALLATION PRINCIPLES

PAGES 4-11

- INSTALLATION ANGLES
- CONNECTIONS TO PURLINS (HANGERS AND CABLES)
- JOINING CABLES
- TRAPEZE CONNECTION DETAILS
- CABLE BRACE ANCHORS

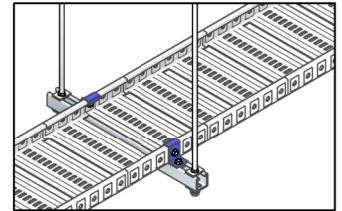
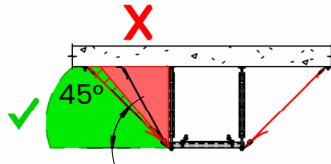
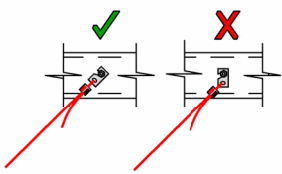

2. SEISMIC CABLE KITS

PAGES 12-14

- TWO-WAY CABLE BRACES
- FOUR-WAY CABLE BRACES
- STACKED CABLE BRACES

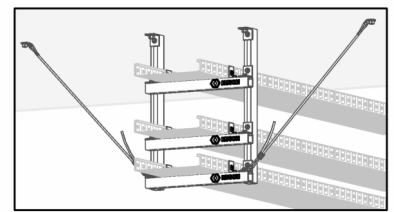
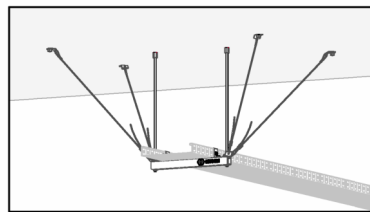
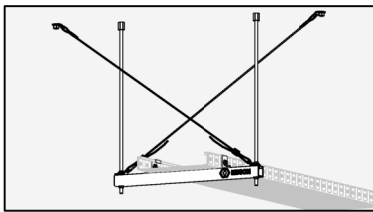

3. STRUT POSTS – K1 & C2/3/4

PAGES 15-17

- SUPA STRUT AND 41mm STRUT
- 2-POST TRAPEZE AND SINGLE POST TRAPEZE

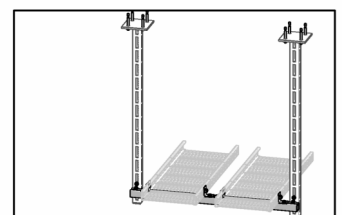
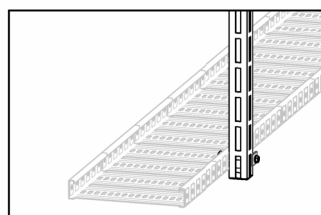
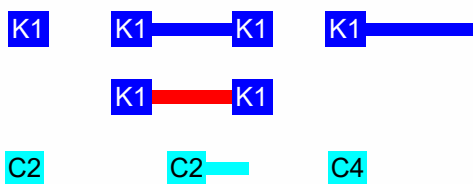

4. 41mm STRUT BRACES

PAGES 18-21

- CANTILEVER WALL BRACES
- BRACES AT WALL PENETRATIONS
- COLUMN CLAMPS
- TRAPEZE BRACES

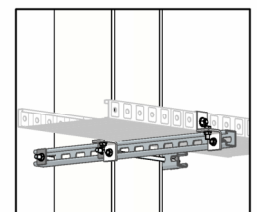
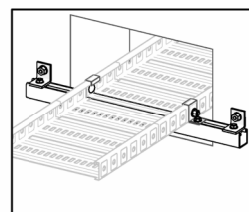
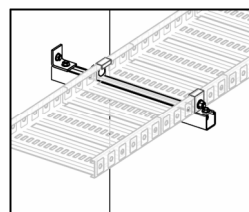
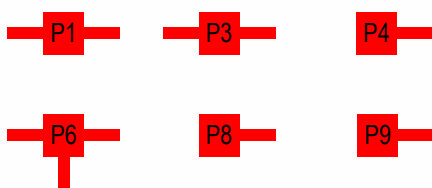

5. SUPA STRUT BRACES

PAGES 22-25

- CANTILEVER POSTS FROM FLOOR OR SOFFIT
- FLOOR-TO-SOFFIT COLUMN

S50	F50	FS50
S80	F80	FS80
S100	F100	FS100

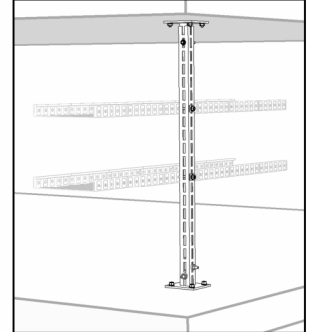
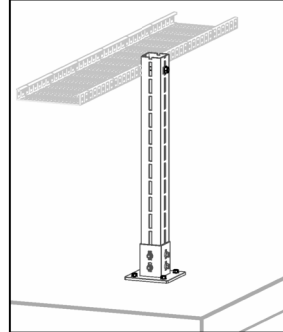
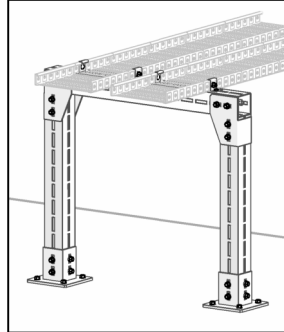

6. ELECTRICAL EQUIPMENT RESTRAINT

PAGES 26-29

- FLOOR MOUNTED SWITCHBOARDS

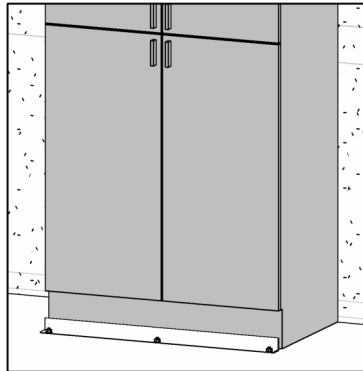

At every instance, use:

- Seismic rated concrete anchors as approved by **KUSCH**.
- 41mm strut washer and locking nut above *and* below trapeze.
- Stiffeners to rod as specified by **KUSCH**.
- M10 (minimum) rod hangers.

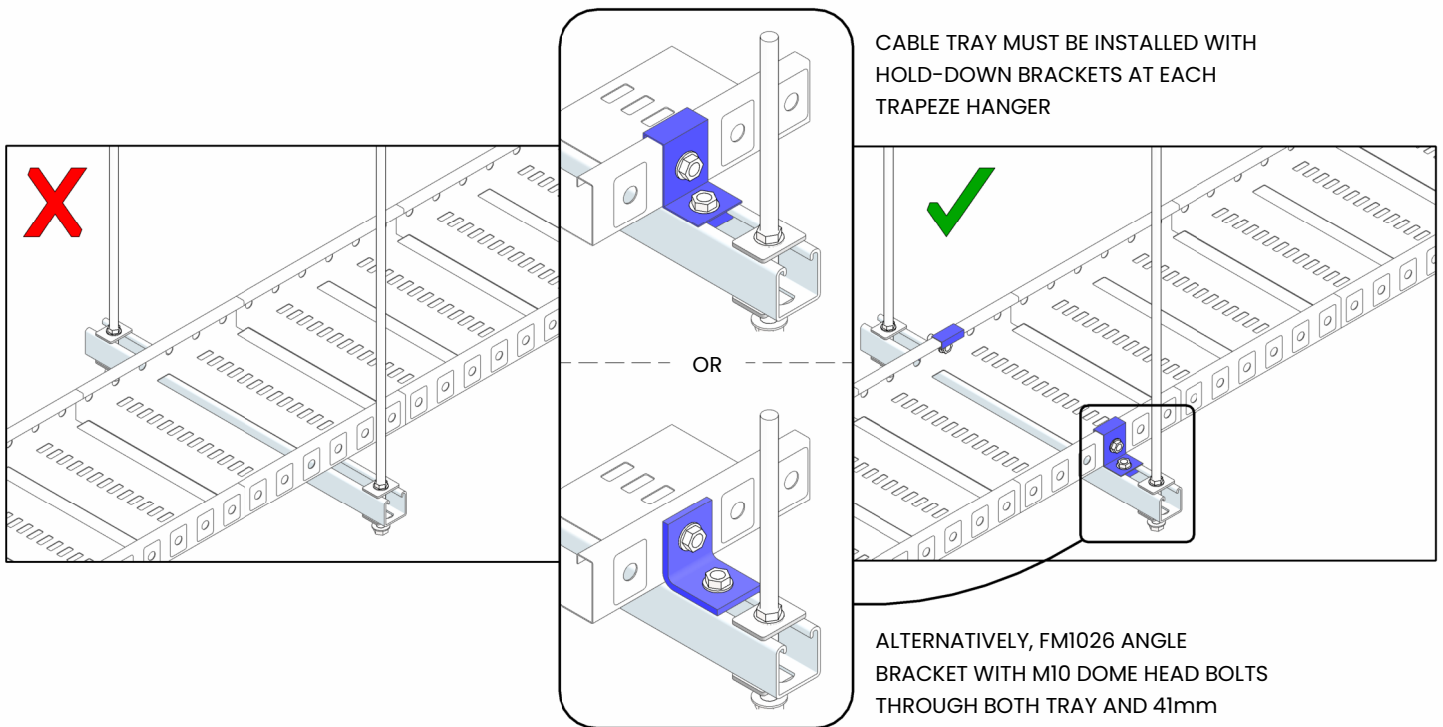

PIPE AND TRAY TRAPEZE DETAIL SECTION

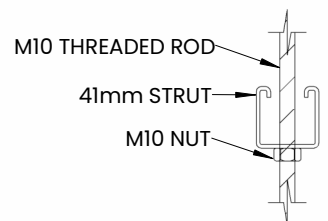
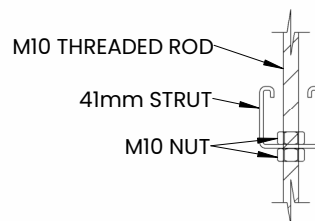
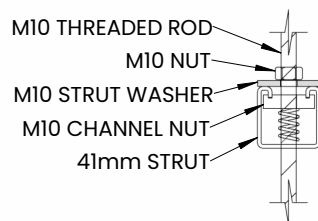
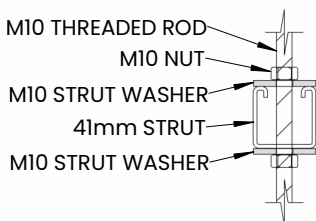

CABLE TRAY HOLD-DOWN BRACKETS WITH M10 NUT/BOLT TO BOTH CABLE TRAY **AND** 41mm STRUT TRAPEZE. TYPICALLY, DOME HEAD BOLTS TO TRAY ARE TO PREVENT BOLT HEAD TEARING CABLES AS THEY ARE PULLED.

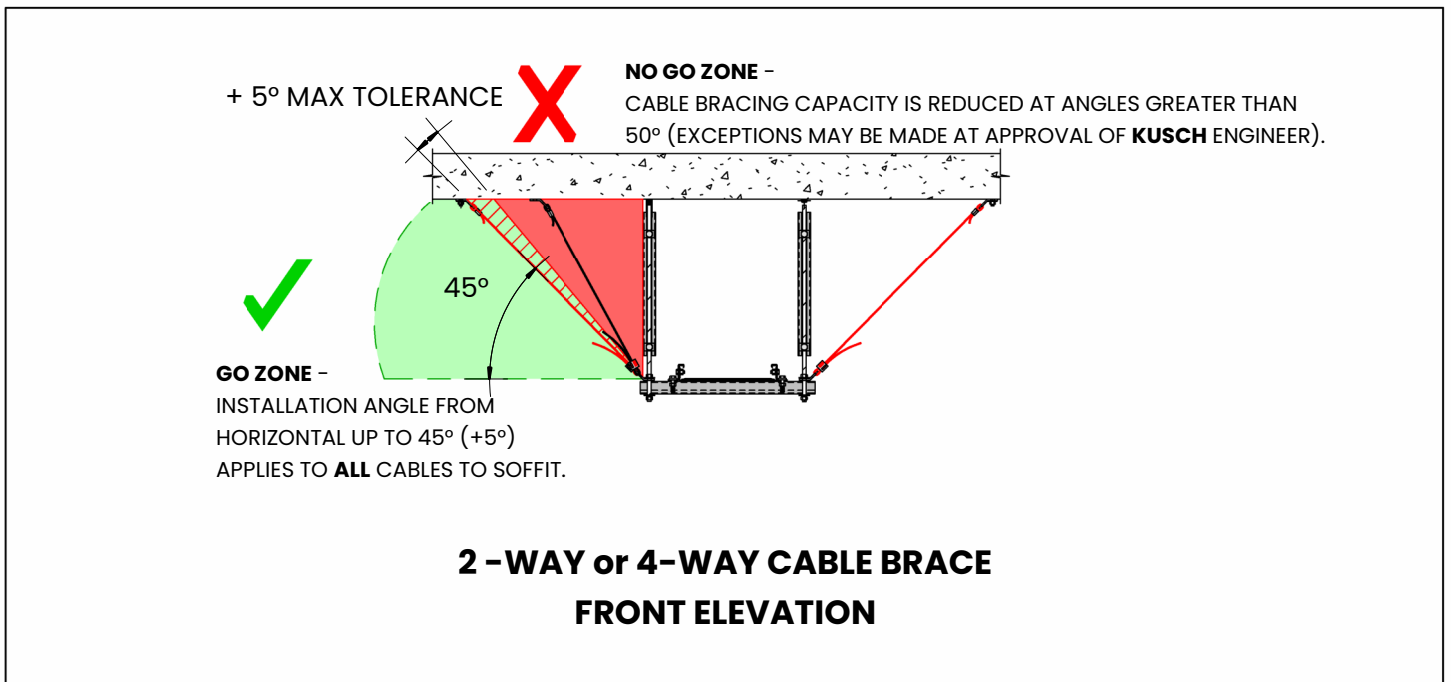
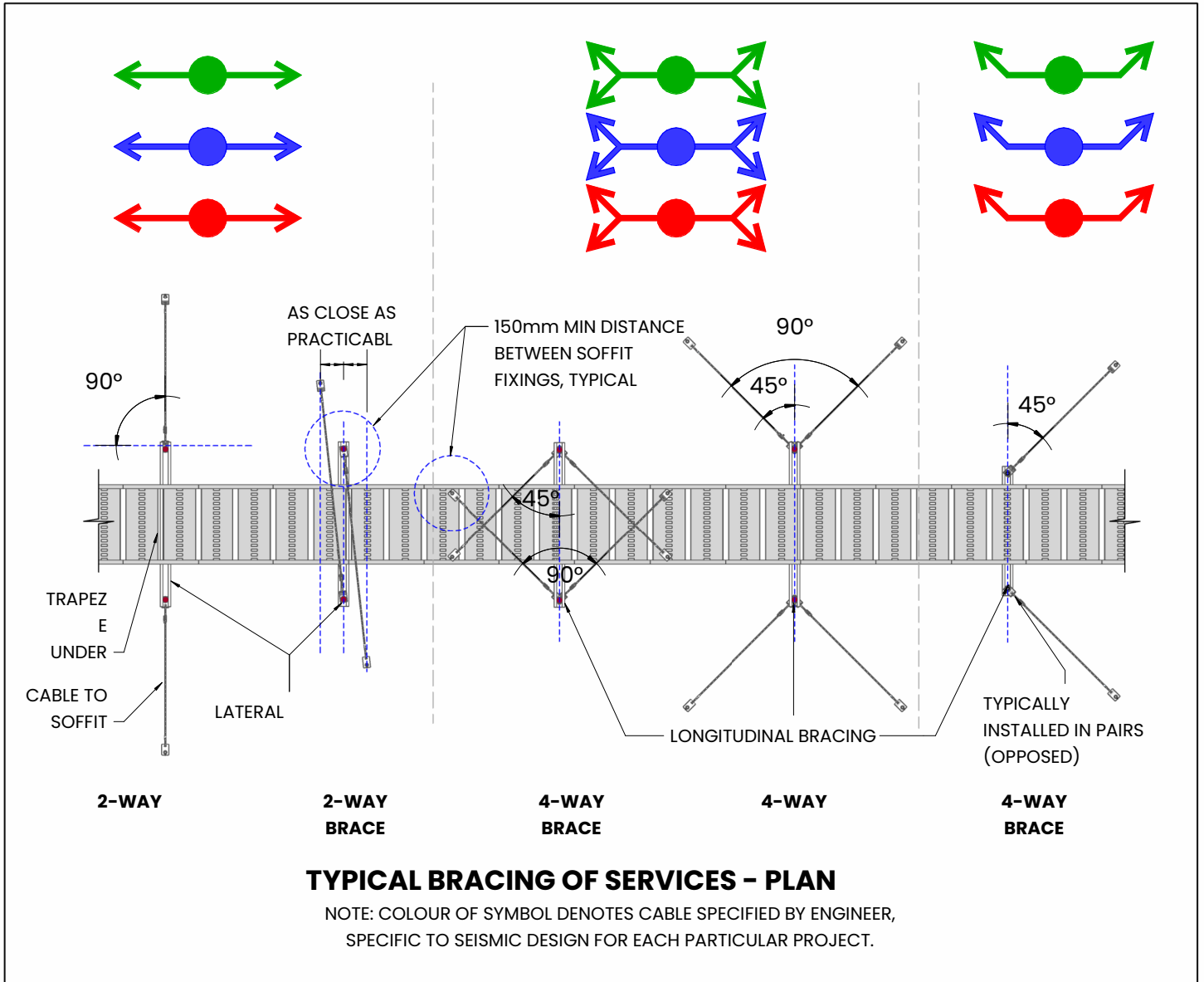

SEISMIC CABLE TO PURLIN CONNECTION DETAIL

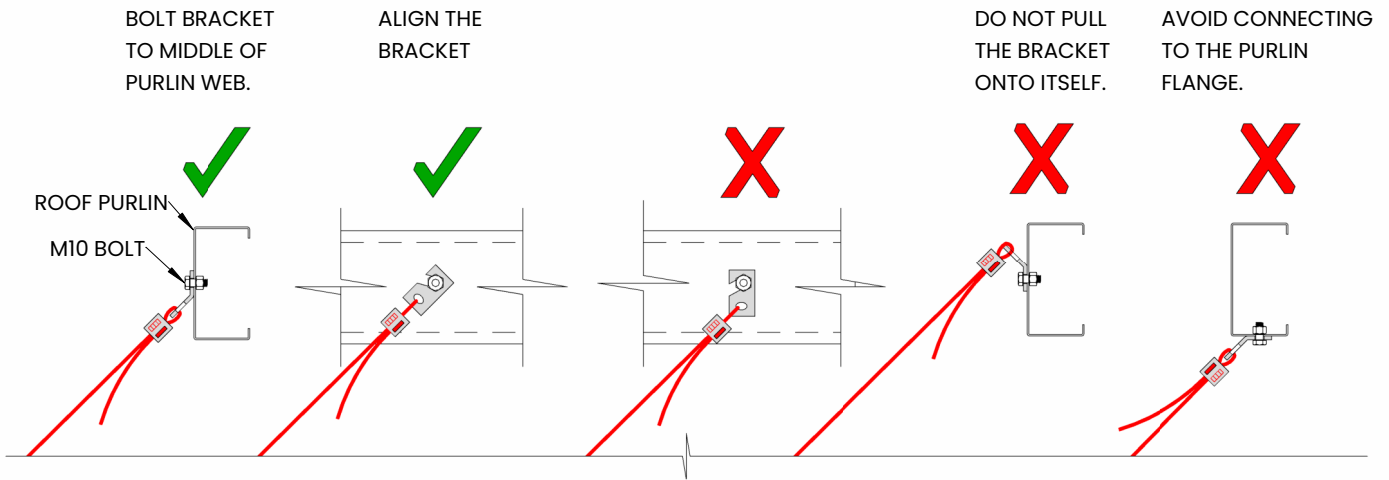

SEISMIC CABLE TO TIMBER TRUSS CONNECTION

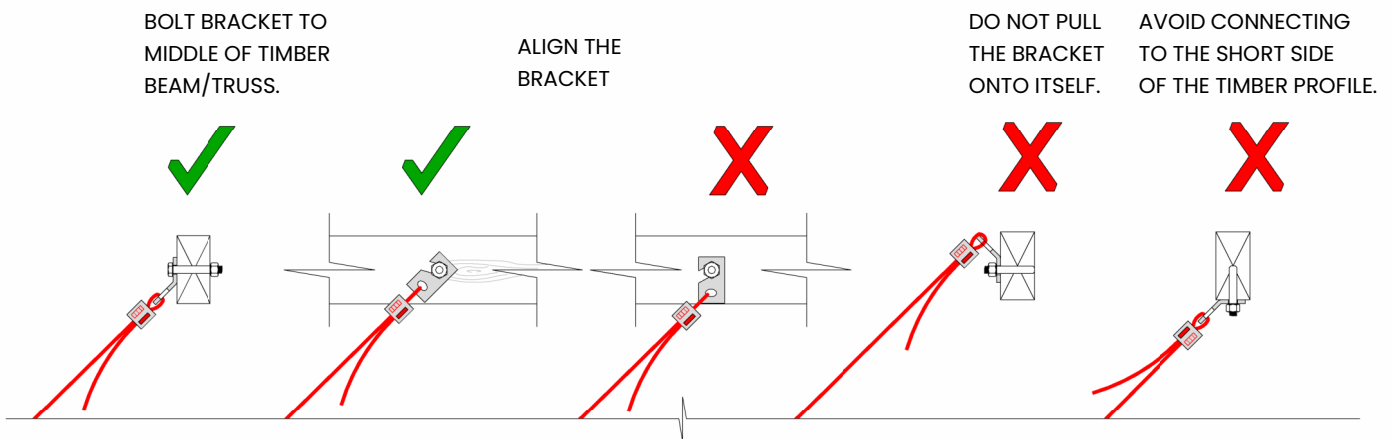

IMPORTANT



DO:

- HAND TIGHTEN CABLE USING ZIP-CLIP CABLE JOINER.
- ADJUST Zip-Clip CABLE JOINER USING RELEASE PINS IF REQUIRED.
- LEAVE A TAIL AT FREE END OF CABLE PASSING THROUGH ZIP-CLIP CABLE JOINER, MIN. 150mm.
- ALIGN 45° ANGLE BRACKETS AT EACH END SO THAT BOTH HOLES ON ANGLE BRACKETS ARE IN LINE WITH CABLE, AND CABLE IS PULLING ON NEAREST HOLE.
- USE ROD STIFFENERS AS SPECIFIED BY **KUSCH**.

DO NOT:

- DO NOT ALLOW CABLE TO CONTACT ANY SERVICE, STRUCTURE, PLANT, HANGING ROD, BRACE ETC. ALONG ITS ENTIRE LENGTH.
- DO NOT ATTACH 2 OR MORE CABLES TO 1off SB /NR 45° ANGLE BRACKET.
- DO NOT OVER-TIGHTEN CABLE IN ABSENCE OF ROD-STIFFENER. IF HANGING ROD BUCKLES, THE CABLE CANNOT PROVIDE ADEQUATE RESTRAINT.
- DO NOT BOLT 45° BRACKETS TO PURLIN FLANGES.

SERVICE HANGER DIRECTLY FROM

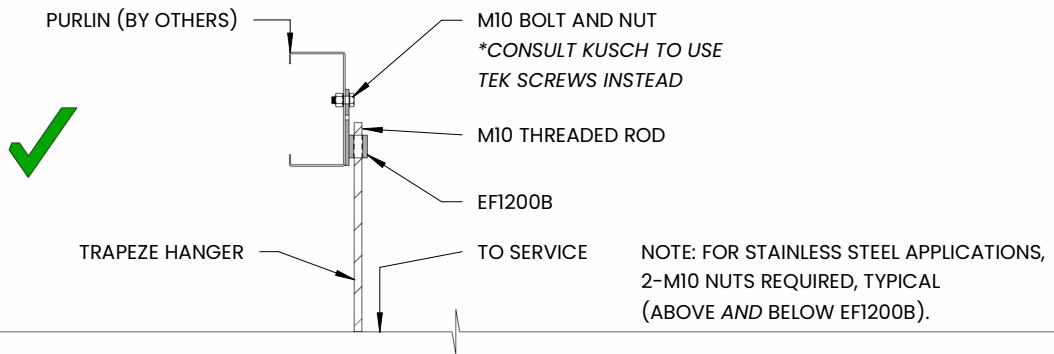

WHERE SERVICE HANGER IS NOT DIRECTLY BELOW

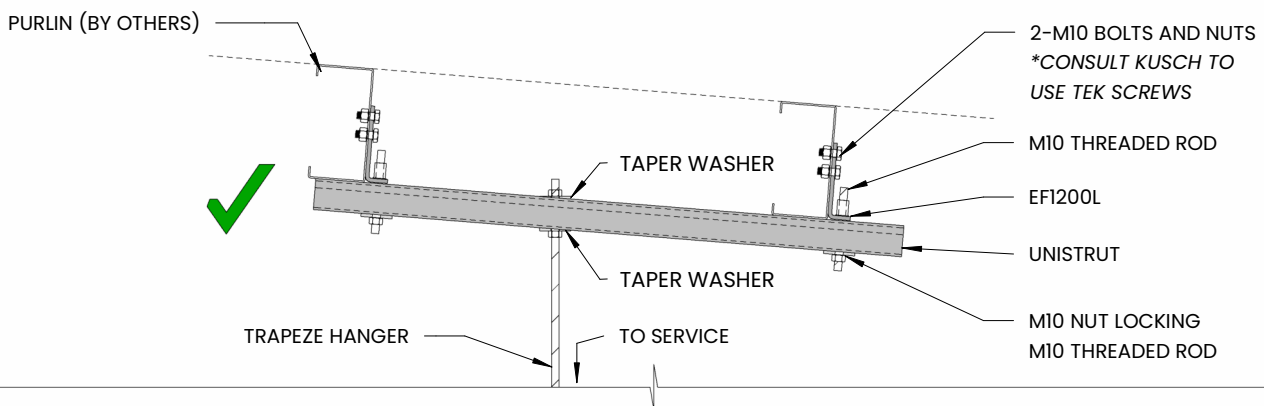
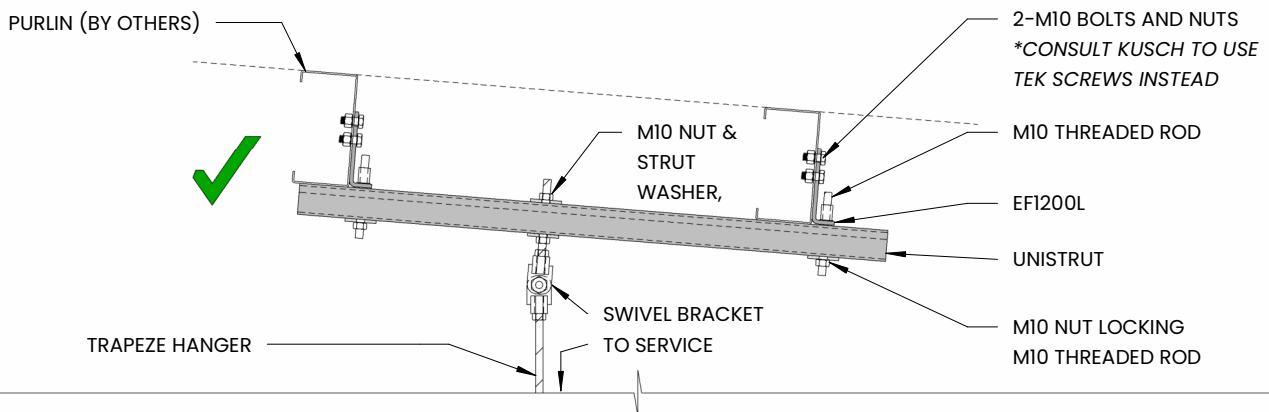
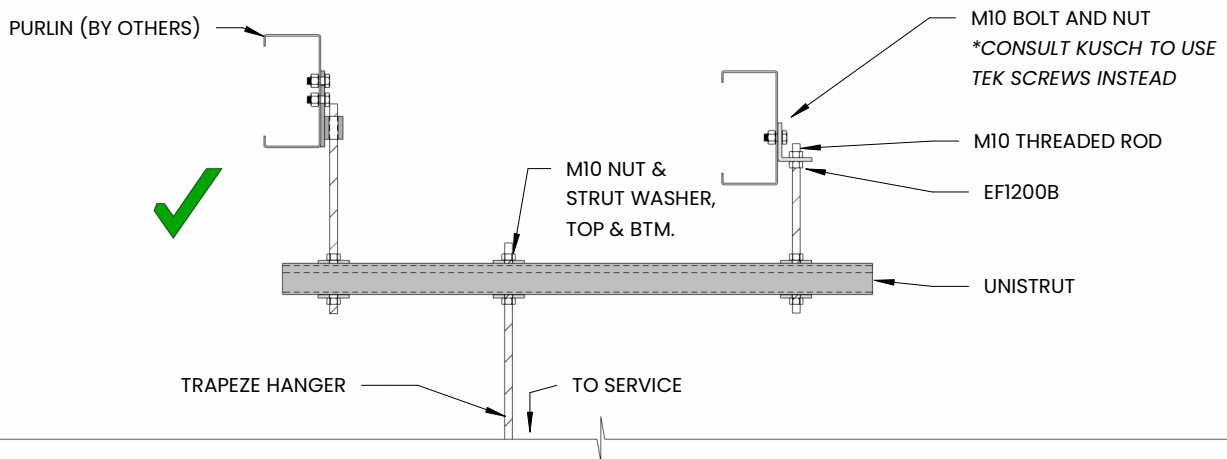

WHERE CABLE CONNECTION DIRECTLY TO PURLIN CANNOT BE ACHIEVED, FIX CABLE AS FOLLOWS

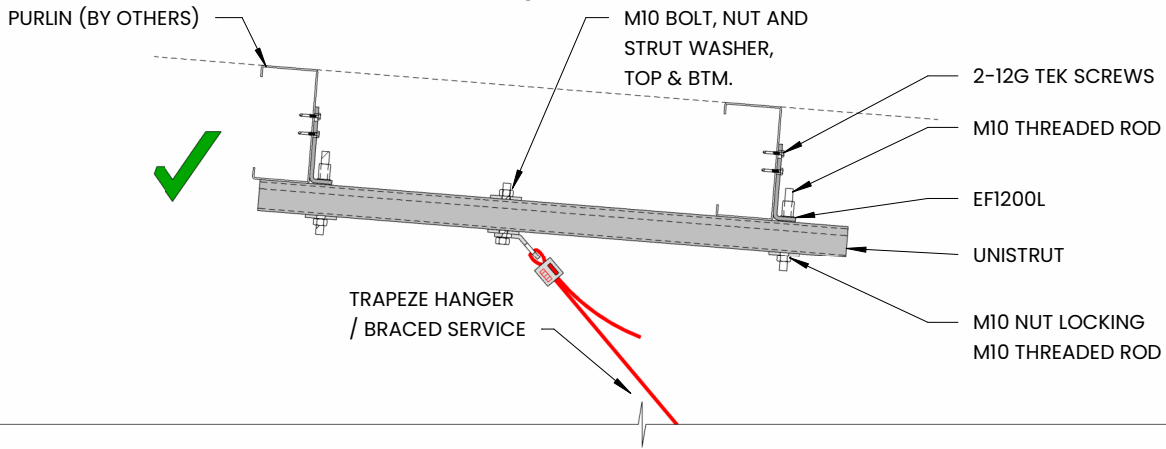

IMPORTANT NOTE:

- Single Red Cable only per strut.
- Minimum 1.2mm thick Purlins.

Otherwise, bolting to purlins required using FM1026 & M10 bolts with Channel nut to strut, and 40x40x3 washer to purlin.

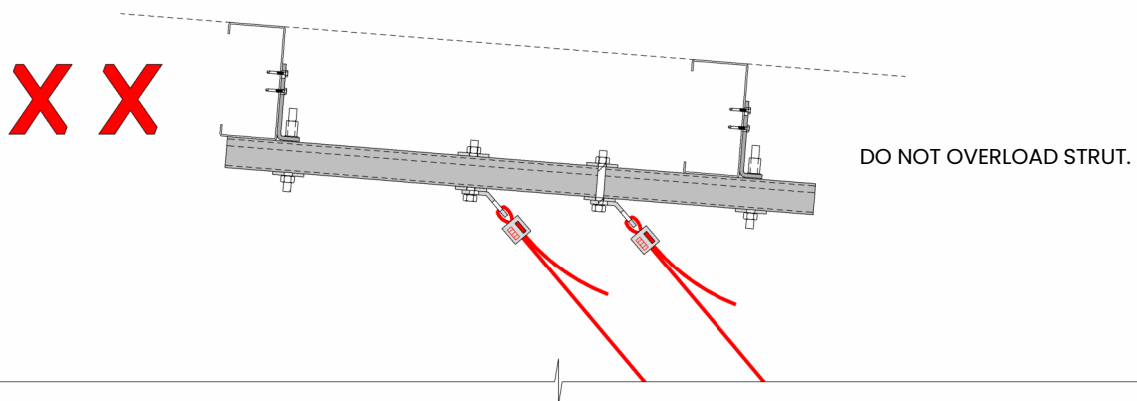
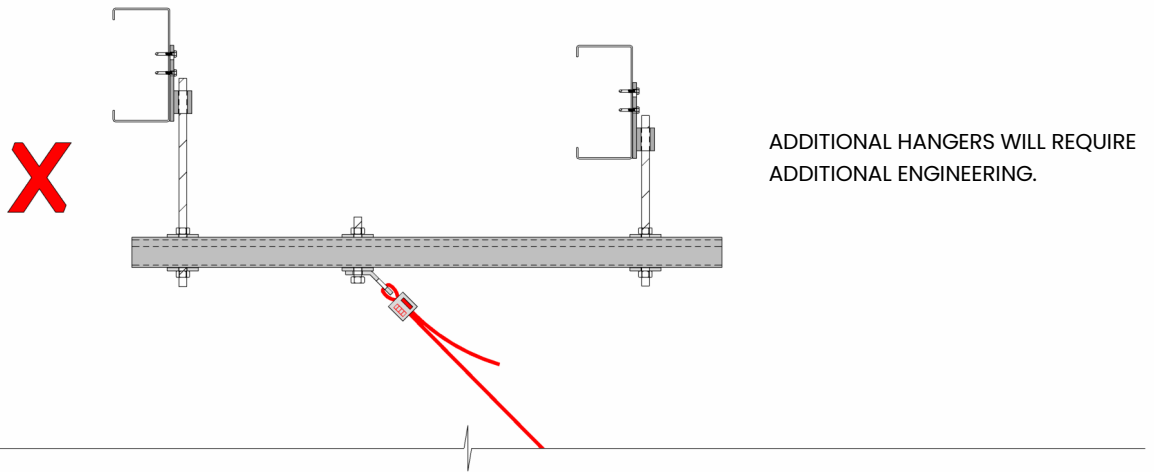

FIXING CABLE TO TYPICAL TRAPEZE

AT EACH CABLE LOCATION,
FIT LARGE PLATE SLOTTED HOLE WASHER IN THE ORIENTATION SHOWN.

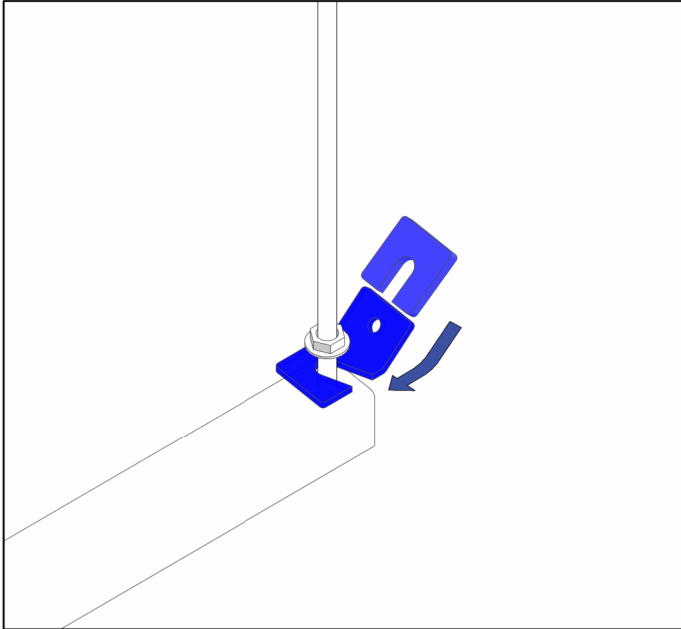

WIND UP TOP M10 NUT AND WASHER, PLACE CABLE BRACKET AND CABLE SLOTTED SQUARE WASHER AS SHOWN.

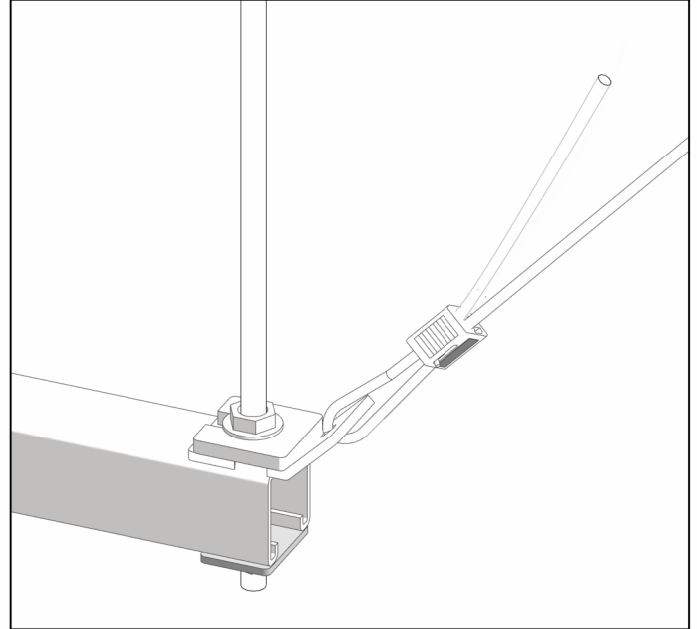

LOCK CABLE BRACKETS TO STRUT TRAPEZE WITH BOTH M10 NUT AND WASHER OVER, AND STRUT WASHER AND M10 NUT UNDER. THEN TENSION CABLES AS PER MANUFACTURERS INSTALLATION SPECIFICATIONS.



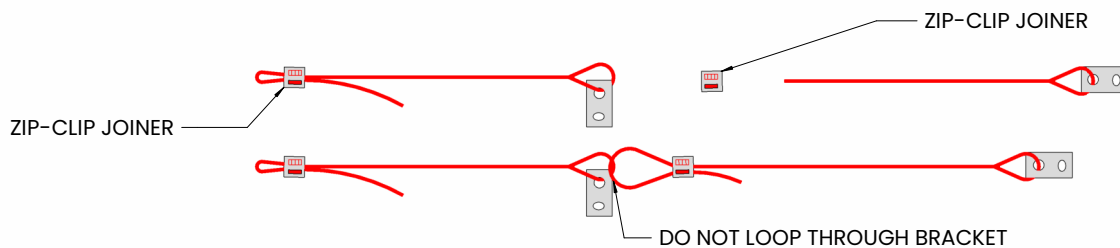

CABLES MAY BE JOINED TO CREATE THE REQUIRED LENGTH BY FOLLOWING OPTION 1 OR 2



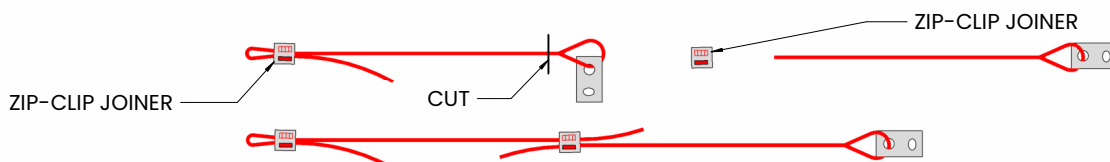

OPTION 1: ELIMINATE BRACKET AND JOIN LOOP-TO-LOOP



OPTION 2: ELIMINATE BRACKET, REMOVE FIXED LOOP WITH WIRE CUTTERS



 ZIP-CLIP SEISMIC RATED BRACE SCHEDULE C1 ANCHORS Brace Angle MAX 45°					
BRACE SYMBOL	Zip-Clip Cable Type	DEWALT Slab Connection	ICCONS Thru-bolt Ultra Slab Connection	HILTI HST4	ICCONS FM753 Slab Connection
	RED (2mm)	M10x90 PTB-ETA1-PRO	M10x90 Thru-bolt Ultra	M10x90 HST4	M10x90 ICCONS-FM753
	BLUE (3mm)		M12x140 Thru-bolt Ultra	M10x90 HST4	M10x90 ICCONS-FM753
	GREEN/YELLOW (4mm)		M12x140 Thru-bolt Ultra	M12x115 HST4	M12x110 ICCONS-FM753

 ZIP-CLIP SEISMIC RATED BRACE SCHEDULE C2 ANCHORS Brace Angle MAX 45°				
Brace Symbol	Zip-Clip Cable Type	HILTI Slab Connection	ICCONS Thru-bolt Ultra Slab Connection	ICCONS FM753 Slab Connection
	RED (2mm)	M10x90 HST4	M10x90 Thru-bolt Ultra	M10x90 ICCONS-FM753
	BLUE (3mm)	M10x90 HST4	M12x140 Thru-bolt Ultra	*M10x90 ICCONS-
	GREEN/YELLOW (4mm)	M12x115 HST4	M12x140 Thru-bolt Ultra	M12x110 ICCONS-FM753

*USING M12x110 ICCONS FM753 FOR A BLUE KIT REQUIRES A SEPARATE PURCHASE OF AN ANGLE BRACKET WITH A 13mm DIAMETER HOLE.

C2 Anchors are usually required in importance level 4 (IL4) buildings.

Please contact **KUSCH** for clarification if you are unsure whether C1 or C2 anchors are required.

If you would like to use an anchor not listed above, please contact **KUSCH** and we will assess the anchor's suitability.

TYPICAL ROD STIFFENER INSTALLATION

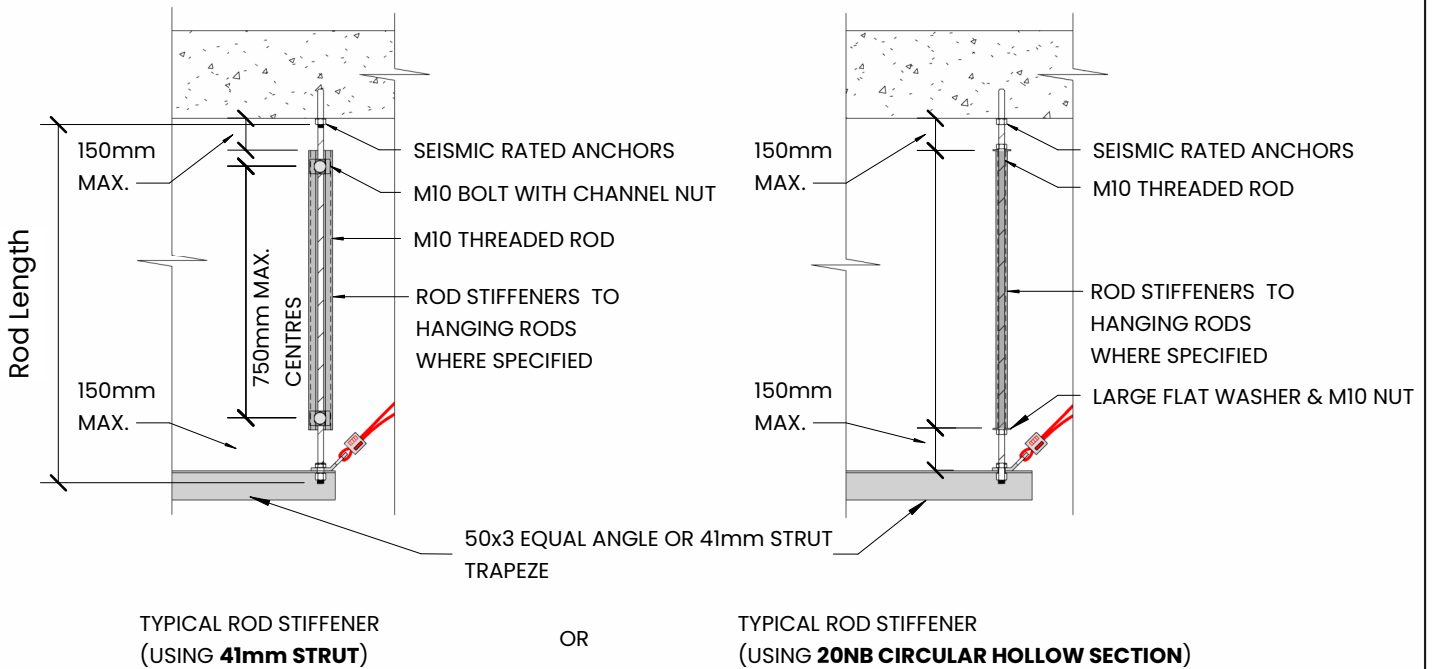

NOTE: INSTALL ROD STIFFENERS WHERE NOTED ON SEISMIC DESIGN DRAWINGS. ENSURE THEY ARE POSITIONED AT TRAPEZE SUPPORTS THAT ALIGN WITH CABLE BRACES.

Rod Stiffeners required > 750mm in IL4 buildings. Otherwise, required as specified. Contact **KUSCH** for removal on a case by case basis once your hanging rod lengths are confirmed.

TYPICAL STRUT ROD STIFFENER CLAMPING METHODS

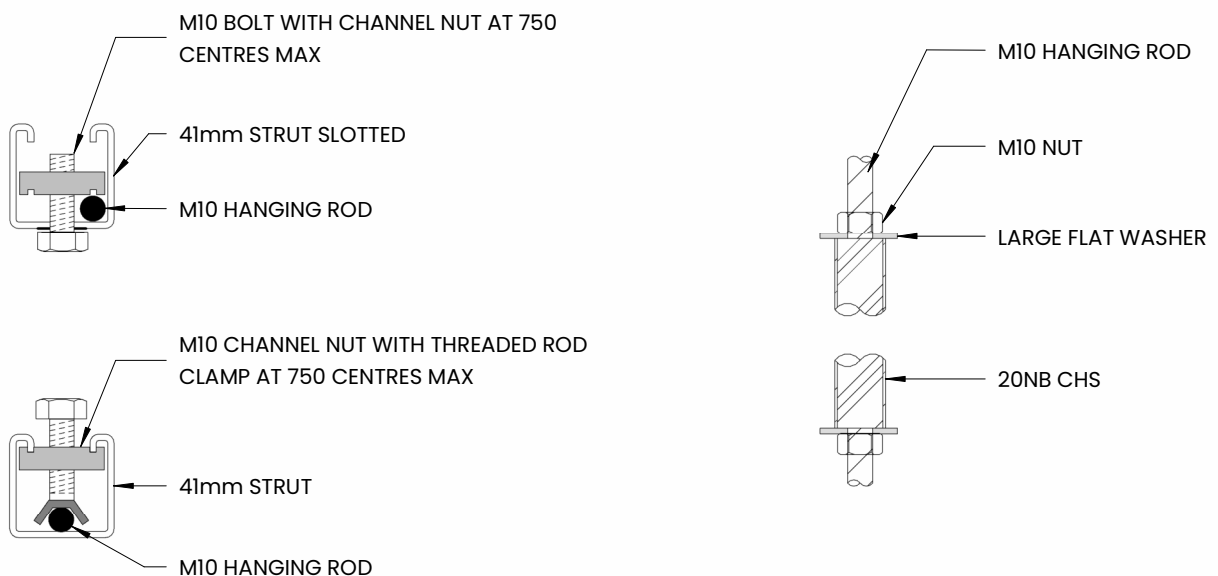

READ THESE INSTRUCTIONS IN CONJUNCTION WITH THE DETAILS IN SECTION 1.0 TO ACHIEVE OPTIMAL CAPACITY FROM CABLE.

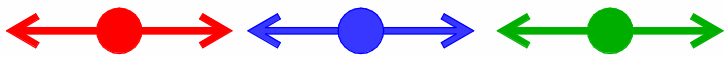

COLOURS DENOTE CABLE SPECIFIED BY SEISMIC DESIGN ENGINEER

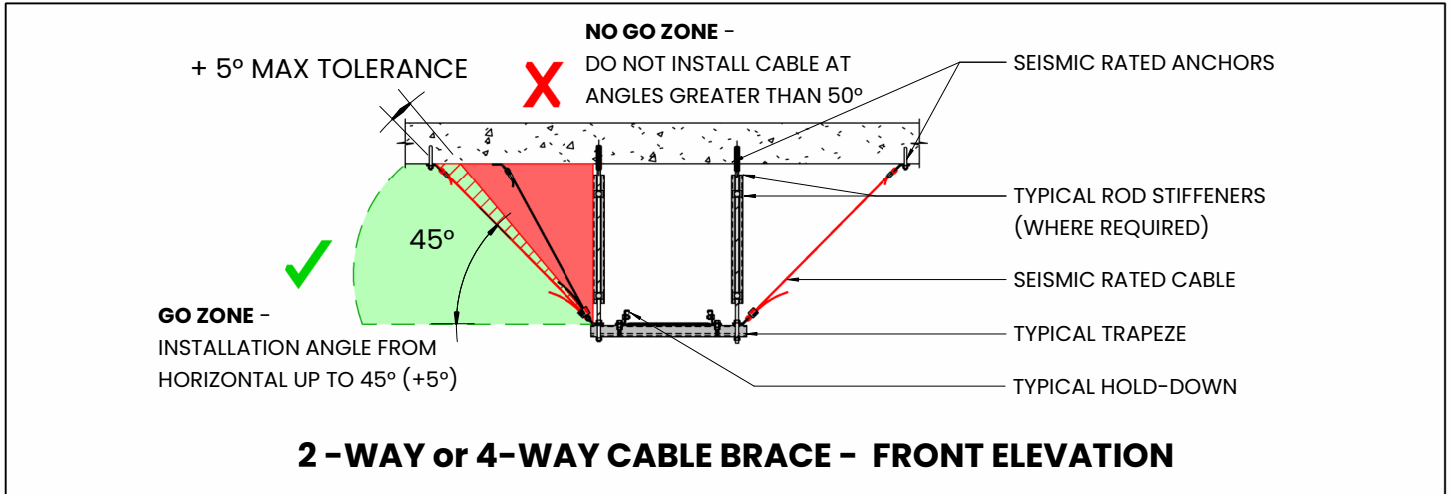

The seismic engineering design may specify 2-way cable braces, these can be **swapped** for variations of a typical 2-way cable trapeze to allow clearance to adjacent services. Likewise for 4-way cable braces.

HOW TO APPLY ALTERNATIVE CABLE BRACE TYPES.

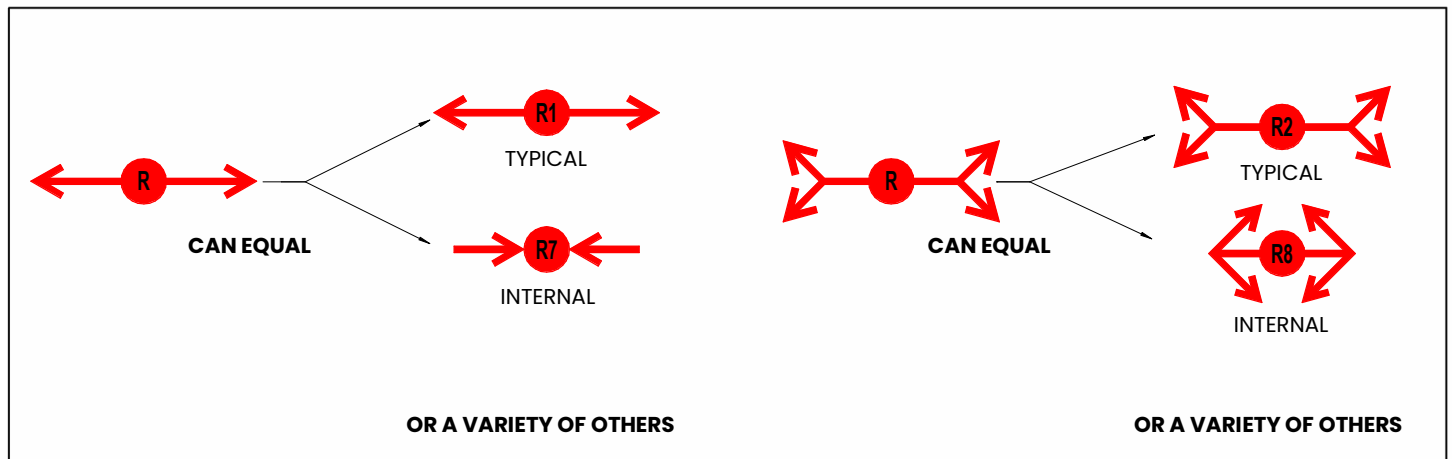

TWO-WAY CABLE KITS OF THE SAME KIT COLOUR ARE INTERCHANGEABLE WITH THESE CONFIGURATIONS: TYPICAL, INTERNAL, MID-MOUNT.

FOUR-WAY CABLE KITS OF THE SAME KIT COLOUR ARE INTERCHANGEABLE WITH THESE CONFIGURATIONS: TYPICAL, MID-MOUNT, INTERNAL.

CLEARANCE AROUND ANCHORS



CLEARANCE TO ANCHORS - 150mm CLEARANCE AROUND ANCHORS

PLEASE READ THESE INSTRUCTIONS IN CONJUNCTION WITH THE DETAILS WITHIN SECTION 1 TO ACHIEVE OPTIMAL CAPACITY FROM CABLES.

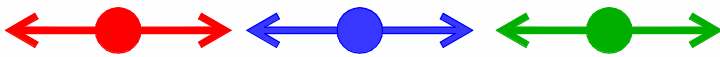

COLOURS DENOTE CABLE SPECIFIED BY SEISMIC DESIGN ENGINEER

TYPICAL 2-WAY (TRAY)	SCHEDULE	
 	TYPE	(R1, B1, or G1) OR (R7, B7 or G7)
	CABLE KIT COLOUR	RED, BLUE or GREEN
	CABLE LENGTH	2m, 3m, or 5m
	CABLE ANCHORS	Qty: 2 Type: AS SPECIFIED (REFER TO SECTION 1 ANCHOR CHART)
	CABLE QTY	2
	MAX. CABLE ANGLE	FROM HORIZONTAL, UP TO 45°
	M10 ROD	LENGTH VARIES
	ROD ANCHORS	Qty: 2 Type: AS SPECIFIED (SEISMIC RATED)
	ROD STIFFENER	WHERE SPECIFIED BY KUSCH
	ROD STIFFENER FIXINGS	@ 700mm CTS (WHERE 41mm STRUT IS USED AS ROD STIFFENER)
	41mm STRUT TRAPEZE	LENGTH VARIES
	STRUT WASHER	4
	FM1008 CHANNEL	2
	M10	6
	M10x35 HEX-HEAD	2
	M10x35 DOME-HEAD	2
HOLD-DOWN BRACKET	2	

OPTION TO ORIENT CABLES INTERNALLY: ALLOW 150mm MIN. CLEARANCE BETWEEN ANCHORS - REFER TO DETAIL ON PREVIOUS PAGE

2-WAY STACKED (TRAY)	SCHEDULE	
 	TYPE	(R3, B3 or G3) OR (R5, B5 or G5)
	CABLE KIT COLOUR	RED, BLUE or GREEN
	CABLE LENGTH	2m, 3m, or 5m
	CABLE ANCHORS	Qty: 2 Type: AS SPECIFIED (REFER TO SECTION 1 ANCHOR CHART)
	CABLE QTY	2
	MAX. CABLE ANGLE	FROM HORIZONTAL, UP TO 45°
	ROD	Qty: 2 Type: AS SPECIFIED (SEISMIC RATED)
	ROD	WHERE SPECIFIED BY KUSCH
	ROD STIFFENER	@ 700mm CTS (WHERE 41mm STRUT IS USED AS ROD STIFFENER)
	41mm	2 HANGERS + 1 / TRAPEZE
	FM1026 ANGLE	2 + 2 / TRAPEZE
	M10x35 HEX-HEAD	2 + 4 / TRAPEZE
	M10 CHANNEL	2 + 6 / TRAPEZE
	M10x35 DOME-HEAD	2 / TRAPEZE
	HOLD-DOWN	2 / TRAPEZE

PLEASE READ THESE INSTRUCTIONS IN CONJUNCTION WITH THE DETAILS WITHIN SECTION 1 TO ACHIEVE OPTIMAL CAPACITY FROM CABLES.



TYPICAL 4-WAY (TRAY)	SCHEDULE	
	TYPE	(R2, B2 or G2) OR (R8, B8 or
	CABLE KIT COLOUR	RED, BLUE or GREEN
	CABLE LENGTH	2m, 3m, or 5m
	CABLE ANCHORS	Qty: 4 Type: AS SPECIFIED (REFER TO SECTION 1 ANCHOR CHART)
	CABLE QTY	4
	MAX. CABLE ANGLE	FROM HORIZONTAL, UP TO 45°
	M10 ROD	LENGTH VARIES
	ROD ANCHORS	Qty: 2 Type: AS SPECIFIED (SEISMIC RATED)
	ROD STIFFENER	WHERE SPECIFIED BY KUSCH
	ROD STIFFENER FIXINGS	@ 700mm CTS (WHERE 41mm STRUT IS USED AS ROD STIFFENER)
	41mm STRUT TRAPEZE	LENGTH VARIES
	STRUT WASHER	4
	FM1008 CHANNEL	2
	M10	6
	M10x35 HEX-HEAD	2
M10x35 DOME-HEAD	2	
HOLD-DOWN BRACKET	2	

OPTION TO ORIENT CABLES INTERNALLY, ALLOW 150mm MIN. CLEARANCE BETWEEN ANCHORS - REFER TO DETAIL IN SECTION 1

4-WAY STACKED (TRAY)	SCHEDULE	
	TYPE	(R4, B4 or G4) OR (R6, B6 or G6)
	CABLE KIT COLOUR	RED, BLUE or GREEN
	CABLE LENGTH	2m, 3m, or 5m
	CABLE ANCHORS	Qty: 4 Type: AS SPECIFIED (REFER TO SECTION 1 ANCHOR CHART)
	CABLE QTY	4
	MAX. CABLE ANGLE	FROM HORIZONTAL, UP TO 45°
	ROD	Qty: 2 Type: AS SPECIFIED (SEISMIC RATED)
	ROD	WHERE SPECIFIED BY KUSCH
	ROD STIFFENER	@ 700mm CTS (WHERE 41mm STRUT IS USED AS ROD STIFFENER)
	41mm	2 HANGERS 1 / TRAPEZE
	FM1026 ANGLE	2 + 2 / TRAPEZE
	M10x35 HEX-HEAD	2 + 4 / TRAPEZE
	FM1008 CHANNEL	2 + 6 / TRAPEZE
	M10x35 DOME-HEAD	2 / TRAPEZE
	HOLD-DOWN	2 / TRAPEZE

SP50 posts are available with welded baseplates, in 750, 1000 & 1500mm lengths.

The fixing methods shown here for K1 (suspended SP50 post) can also be applied to floor fixed SP50 post (K1f) and wall fixed K1.

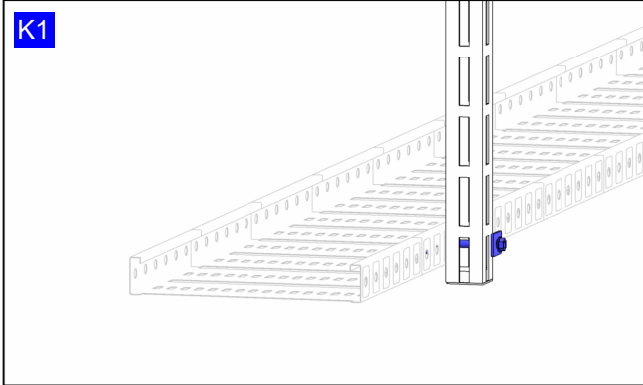

FIX TRAY TO POST WITH M10x75 DOME-HEAD BOLT AND STRUT WASHER THROUGH SP50. ALTERNATIVELY USE SP50-1068 (90° BRACKET) TO TRAY AND POST.

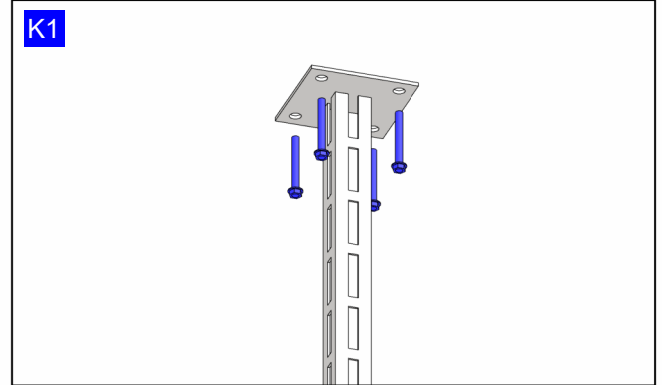

FIX 4- HILTI M10x90 HUS-H **OR** HILTI M10x90 HST4 **OR** M10x90 ICCONS FM753 **OR** APPROVED EQUIVALENT. ALL INSTALLED IN ACCORDANCE WITH MANUFACTURERS SPEC. 80mm MIN. EDGE DISTANCE.

Alternative fixing options for K1 posts to tray.

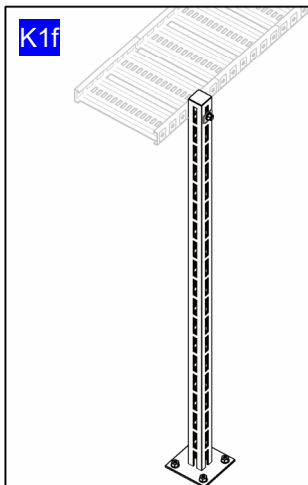

TYPICAL K1 AS PER ABOVE, SHOWN FIXING TO FLOOR

ALTERNATIVE TO TYPICAL K1, WHERE POST HEIGHT IS GREATER THAN 1500mm. SLEEVE 41mm STRUT TO SP50 WITH 2-M10 BOLTS & FM1008 AT MIN 300 CENTRES. FIX 41mm STRUT TO TRAY WITH M10 DOME-HEAD BOLT AND HEXNUT

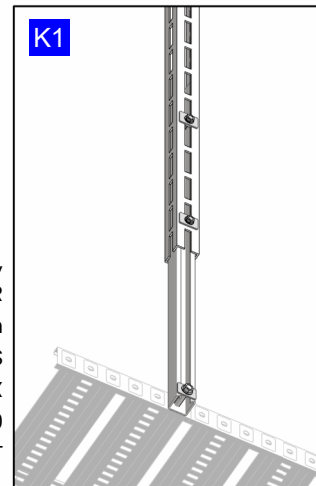

NOTE: SUPA50 POSTS ARE AVAILABLE IN 1500, 1000 & 750mm LENGTHS.

FIX 4- HILTI M10X90 HUS-H OR HILTI M10X90 HST4 OR M10X90 ICCONS FM753 OR APPROVED EQUIVALENT. ALL INSTALLED IN ACCORDANCE WITH MANUFACTURERS SPEC. 80MM MIN. EDGE DISTANCE.

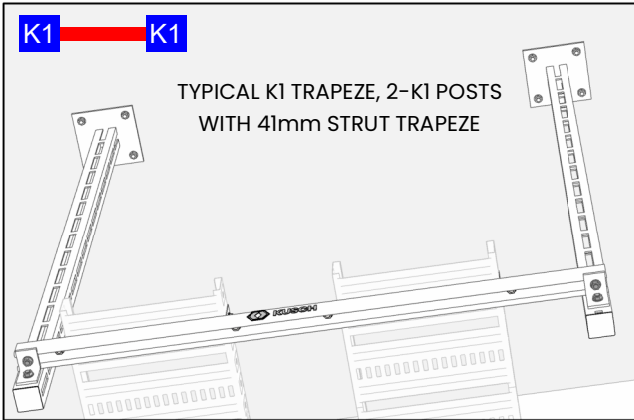

K1 TRAPEZE WITH 41mm STRUT. FIX 41mm STRUT TO K1 POST WITH FM1026, M10 BOLTS AND FM1008. STRUT WASHER TO M10 BOLT THROUGH POST TO FM1026. SAFETY CAP AS REQUIRED.

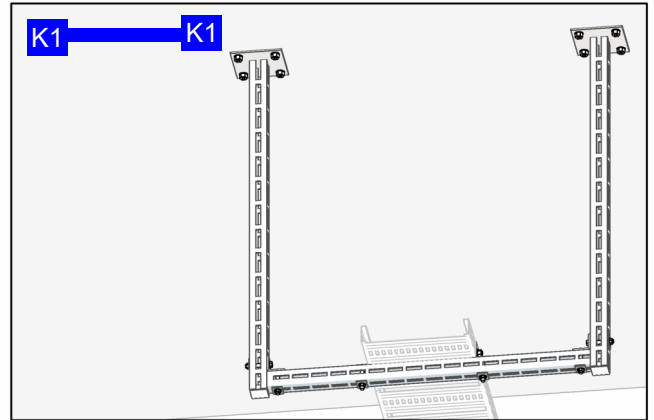

K1 TRAPEZE WITH SUPA50 STRUT. FIX SP50 TO K1 POST WITH FM1026 AND M10 BOLTS THROUGH TO STRUT WASHER. FIX HOLD-DOWN BRACKETS WITH M10 BOLT THROUGH SAFETY CAP AS REQUIRED.

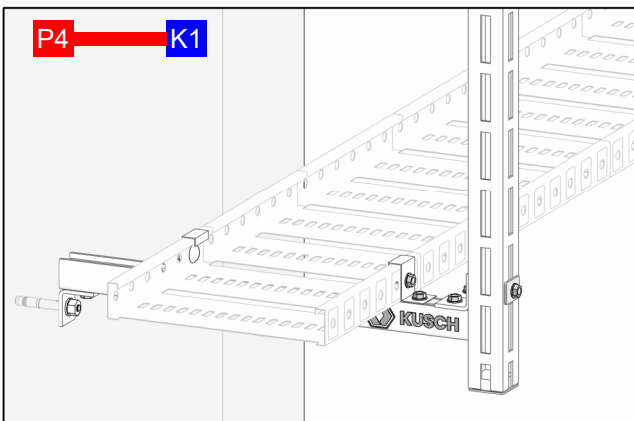

VARIATION OF K1 POST WHERE TRAPEZE IS ADDED TO THE POST WITH AN FM1026 ANGLE BRACKET AND M10 NUT AND BOLT. THIS ALLOWS POST TO CLEAR NEARBY OBSTACLES, OR TO FIX TO THE SOFFIT APPROPRIATELY.

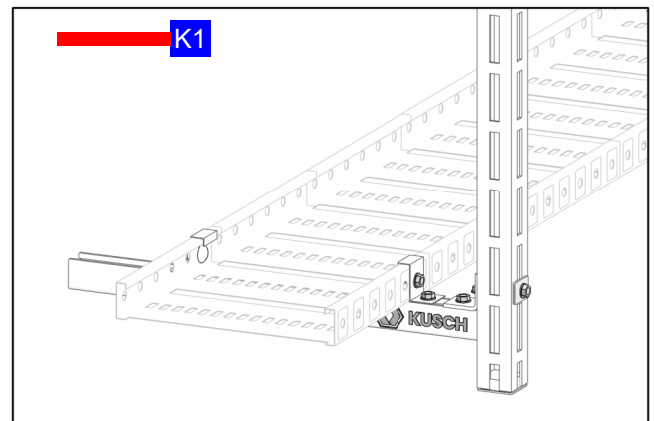

Apply the same fixing methodology to wall mounted K1 as floor or soffit fixed. Ensure wall is concrete or core filled blockwork.

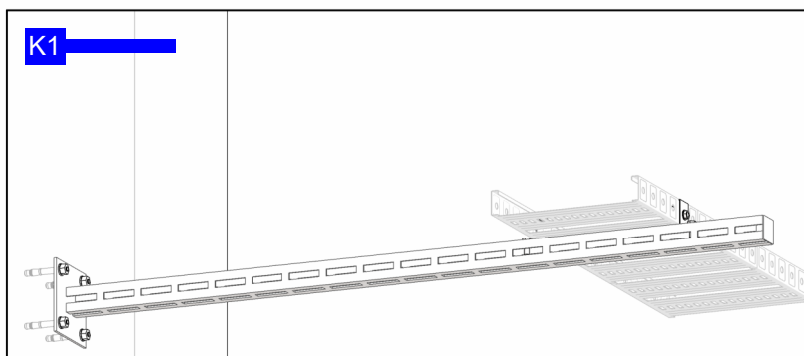

TYPICAL K1 POST CANTILEVERED FROM WALL

C2 & C4 can be applied to tray in all the ways K1 posts can, at reduced capacity, as specified by the design engineer.

FIX FM2073 WELDED 41mm STRUT WITH 4-HILTI M10x90 HST4 **OR** 4-M10x90 ICCONS FM753 **OR** APPROVED EQUIVALENT. ALL INSTALLED IN ACCORDANCE WITH MANUFACTURERS SPEC. 80mm MIN. EDGE DISTANCE.

NOTE: FM2073 (L) LENGTHS ARE MADE TO ORDER.

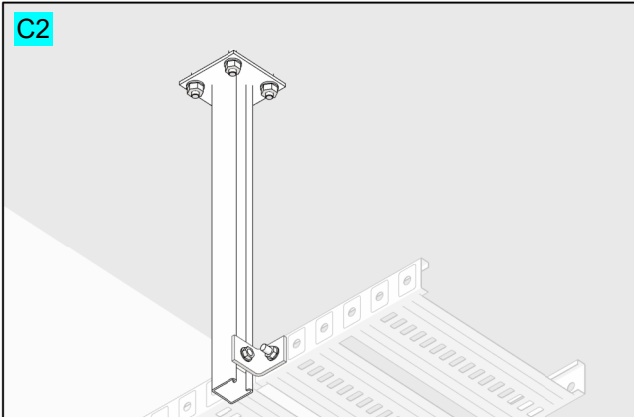

FIX TO TRAY WITH ANGLE BRACKET AND M10 DOME-HEAD BOLT, NUT, HEX-HEAD BOLT AND FM1008.

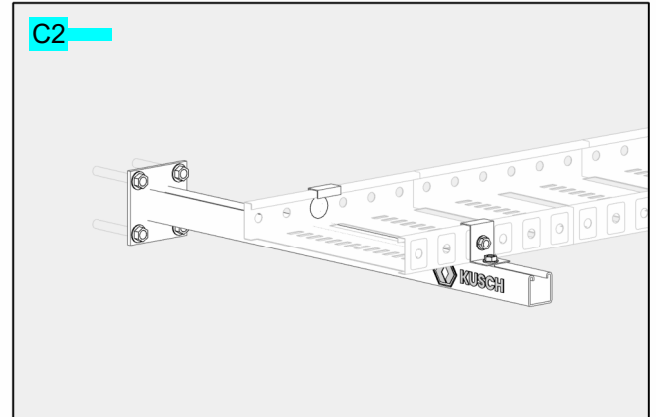

FIX TO TRAY WITH TYPICAL HOLD DOWN BRACKETS.

FM2072 BOLTED BASEPLATE

41mm STRUT BASEPLATE WITH 4-M10 SEISMIC RATED ANCHORS.
2-M10x35 G4.6 BOLTS THROUGH STUB TO FM1008 WITHIN STRUT.

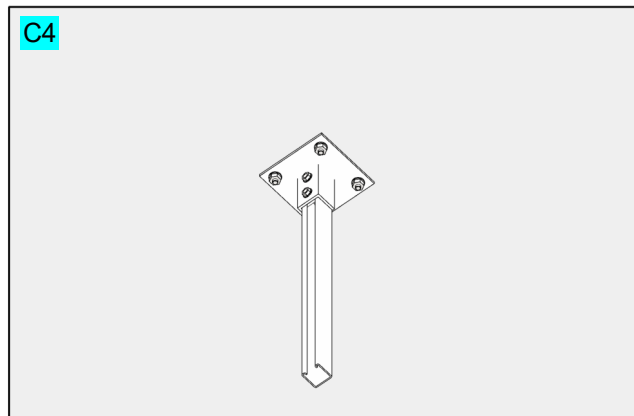

HOLD DOWN BRACKETS WITH DOME HEAD BOLTS TO TRAY, AND M10 BOLTS AND CHANNEL NUTS TO 41mm STRUT APPLIES TO ALL SEISMIC BRACES.

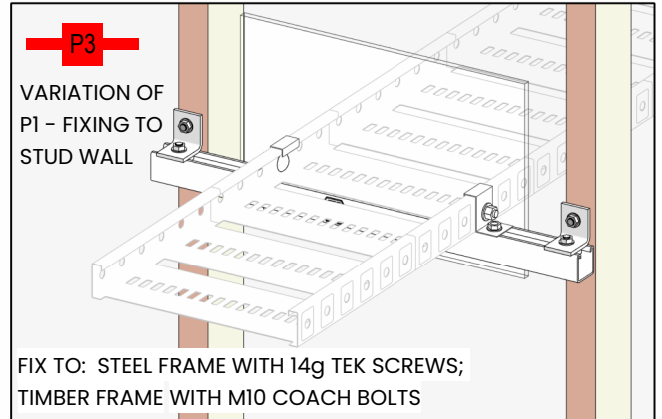
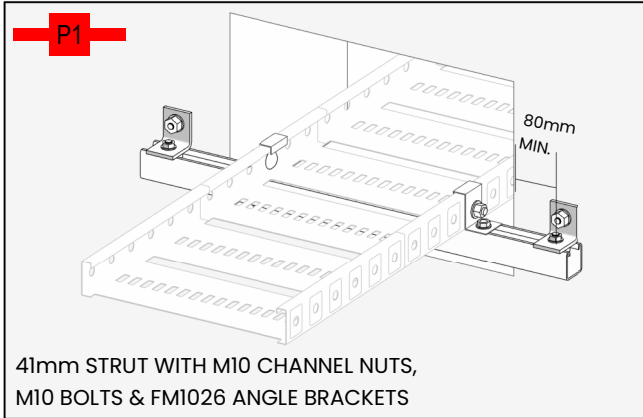

**FOR FIRE RATED WALL,
MAX 10G TEKS SCREWS THROUGH FIRECHECK PLASTER.
ADVISE KUSCH BEFORE DRILLING FIRE RATED WALLS.**

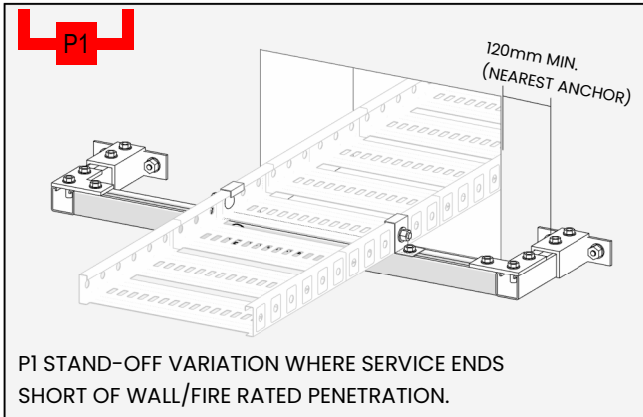

FM2346 BRACKET TO WALL WITH 2-M12 SEISMIC RATED ANCHORS AND 2-M12 BOLTS AND CHANNEL NUTS TO SHORT PIECE OF 41mm STRUT. FM1036 BRACKET WITH 3-M12 BOLTS AND CHANNEL NUTS JOIN 41mm STRUT.

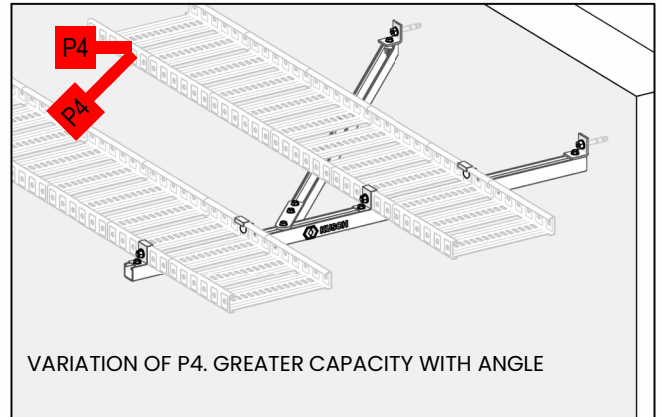

41mm STRUT WITH M10 CHANNEL NUTS, M10 BOLTS & FM1026 ANGLE BRACKETS. FM2324 BRACKET WITH 3-M10 BOLTS AND CHANNEL NUTS JOIN 41mm AT 45°.

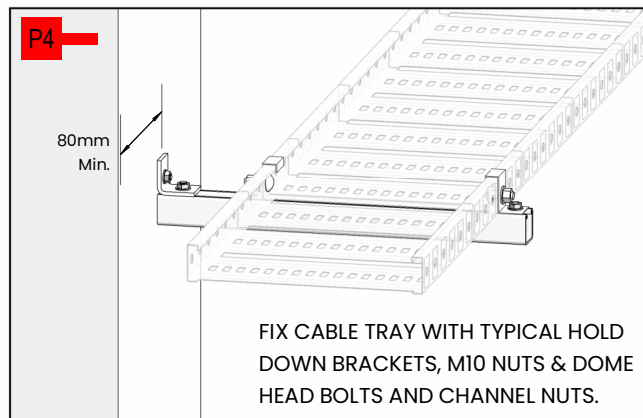

P4 BRACE CAN BE PLACED AT TYPICAL TRAPEZE HANGER BY EXTENDING TRAPEZE TO WALL AND FIXING TO WALL WITH BRACKET.

ANCHORS TO CONCRETE/CORE-FILLED BLOCK WALL TO BE HILTI M10x90 HUS-H OR HILTI M10x90 HST4 OR M10x90 ICCONS FM753 OR APPROVED EQUIVALENT. (ALL ACCORDING TO MANUFACTURERS SPEC). 80mm MINIMUM FROM WALL EDGE.

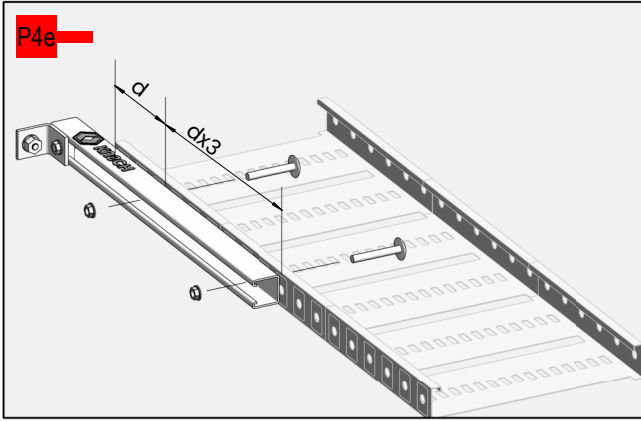

FIX P4e (END) PARALLEL TO TRAY WITH TWO M10x35 DOME-HEAD BOLTS. ENSURE DISTANCE BETWEEN FIXINGS IS 3x DISTANCE FROM WALL U.N.O.

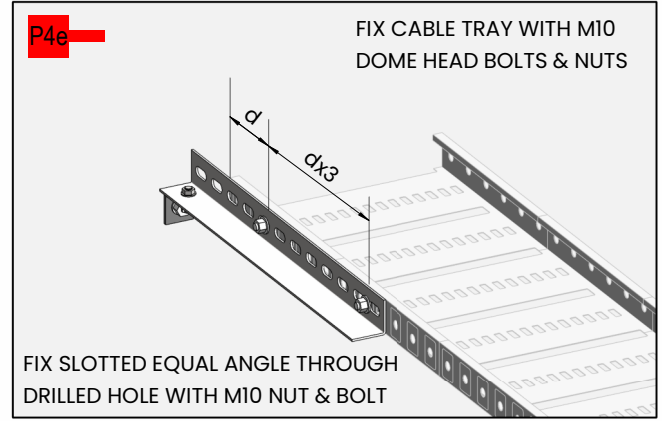

FIX SLOTTED EQUAL ANGLE THROUGH DRILLED HOLE WITH M10 NUT & BOLT

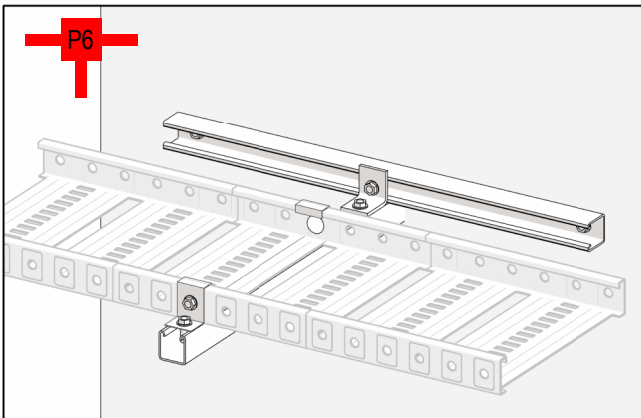

P6 TO CONCRETE/CORE-FILLED BLOCK WALL.

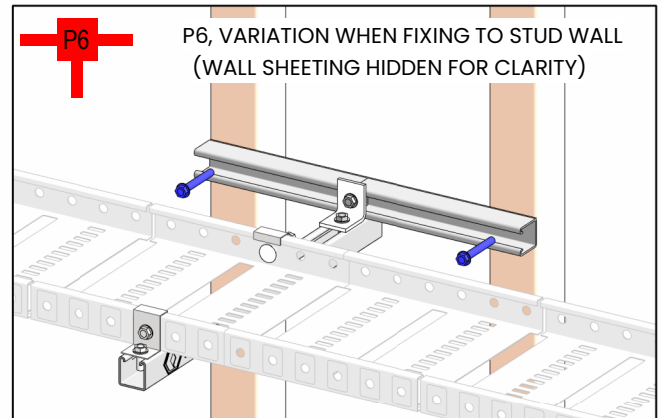

FIX TO: STEEL FRAME - 14g TEK SCREWS; TIMBER FRAME - M10 COACH BOLTS

**FOR FIRE RATED WALL,
MAX 10G TEKS SCREWS THROUGH FIRECHECK PLASTER.
ADVISE KUSCH BEFORE DRILLING FIRE RATED WALLS.**

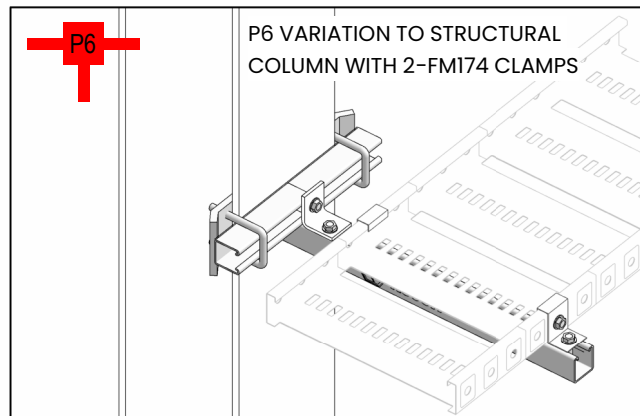

P6 VARIATION TO STRUCTURAL COLUMN WITH 2-FM174 CLAMPS

FIX TO: CONCRETE / CORE-FILLED BLOCK WALL WITH HILTI M10x90 HUS-H OR HILTI M10x90 HST4 OR M10x90 ICCONS FM753 OR APPROVED EQUIVALENT. (ALL ACCORDING TO MANUFACTURERS SPEC.)

TYPICAL P9 TO CONCRETE, CORE FILLED OR STUD WALL

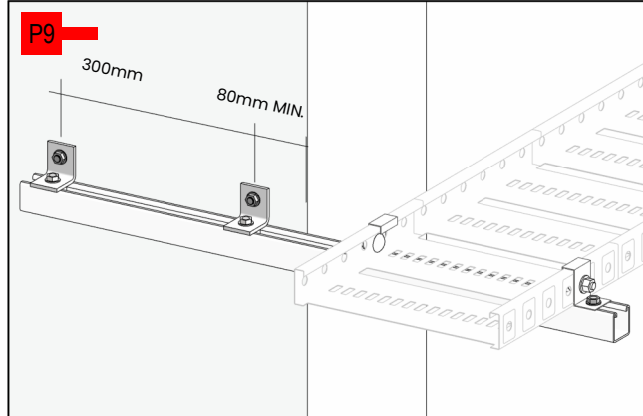

FIX TRAY WITH TYPICAL TRAY CLIPS, M10 BOLTS & CHANNEL NUTS

P9, VARIATION TO STRUCTURAL COLUMN WITH SLOTTED STRUT AND FM1063 STRUT WASHERS TO BOTH SIDES OF M10 ROD

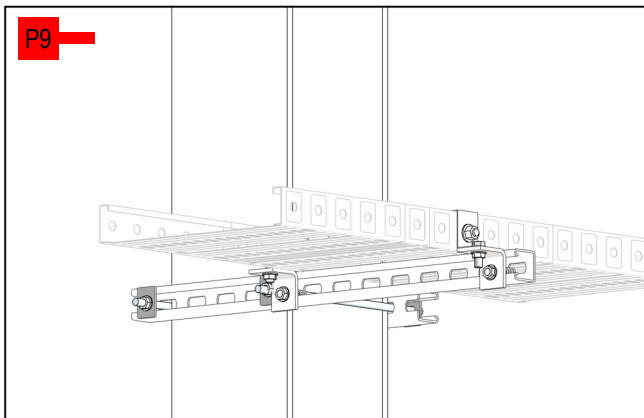

P9, VARIATION TO STRUCTURAL COLUMN WITH SLOTTED 50x3 EA AND LARGE FLAT WASHERS TO BOTH SIDES OF M10 ROD

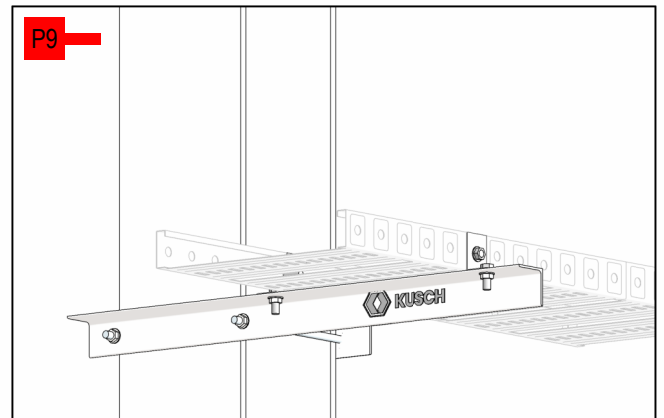

DETAILED PLAN VIEW

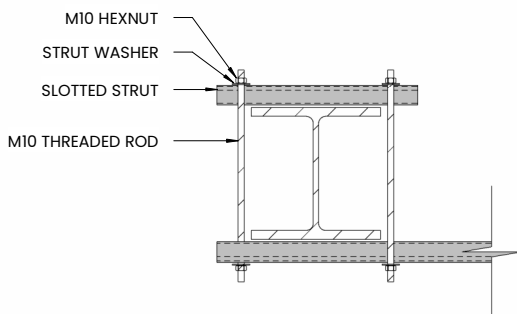

P9 WITH STRUT

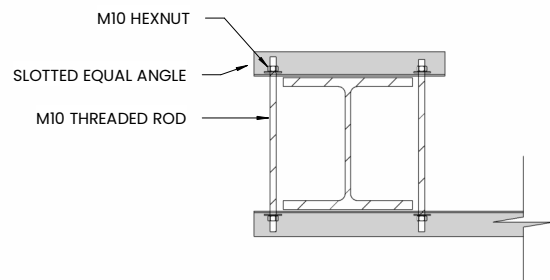

P9 WITH EQUAL ANGLE

FM1546 BRACKETS TO SOFFIT WITH HILTI M10x90 HUS-H **OR** HILTI M10x90 HST4 **OR** M10x90 ICCONS FM753 **OR** APPROVED EQUIVALENT. ALL INSTALLED IN ACCORDANCE WITH MANUFACTURERS SPEC.80mm MIN. EDGE DISTANCE.

TYPICAL P8 SET OUT.

DISTANCE FROM HANGER **EQUALS** HEIGHT OF HANGER (ACHIEVE 45°).

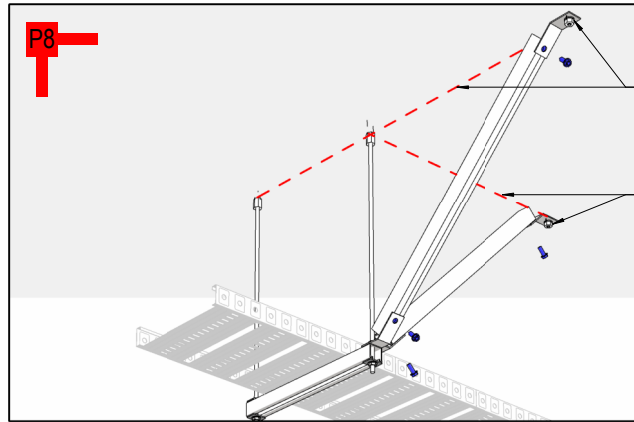

OPTION TO USE E1354 HINGE WHERE FM1546 IS UNSUITABLE. MAINTAIN ANGLES FLATTER THAN 45°.

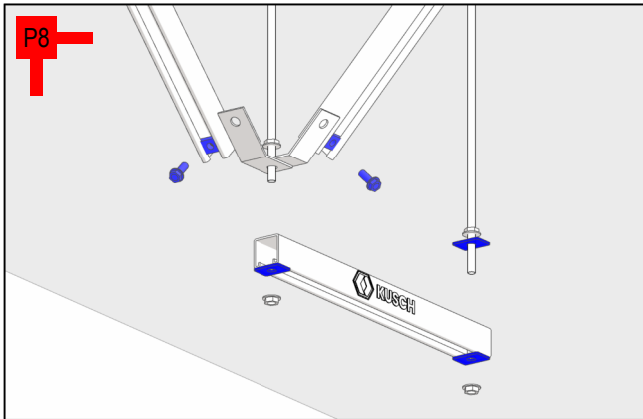

FM1546 BRACKETS TO HANGING RODS ABOVE STRUT TRAPEZE, STRUT WASHERS ELSEWHERE. M12 BOLTS TO FM1546 / E1354 WITH FM1010.

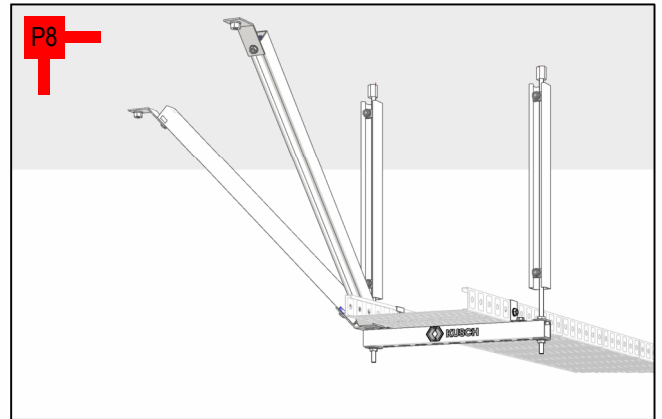

FIX TRAY WITH HOLD-DOWN BRACKETS, M10 BOLTS, NUTS AND CHANNEL NUTS.

VARIATIONS ON P8 AS APPLIED BY DESIGN ENGINEER TO SPECIFIC SCENARIOS

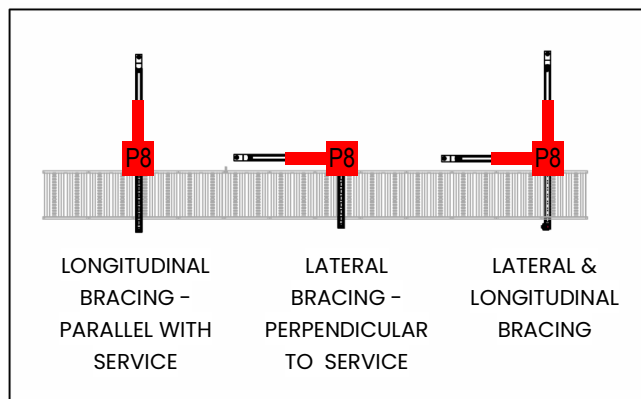

TYPICAL GRAPHICAL REPRESENTATION – PLAN

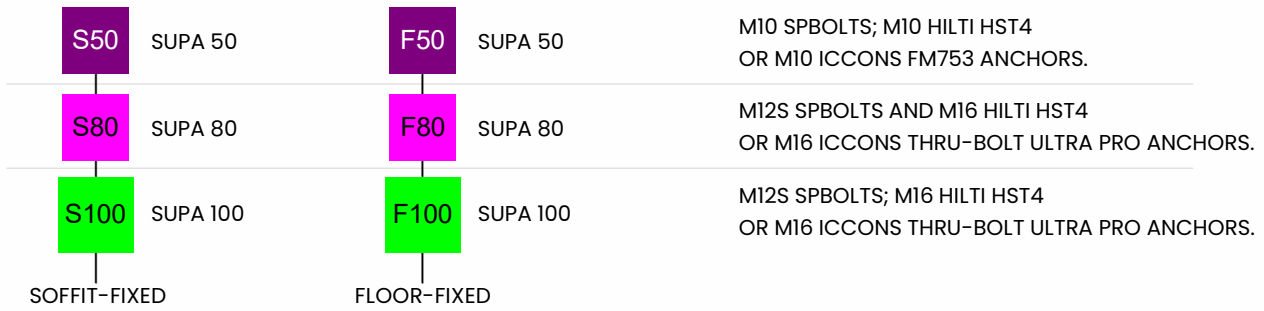

Tray fixing method similar **across all types** (SP100, SP80 & SP50) floor, soffit and floor-soffit (column) types.

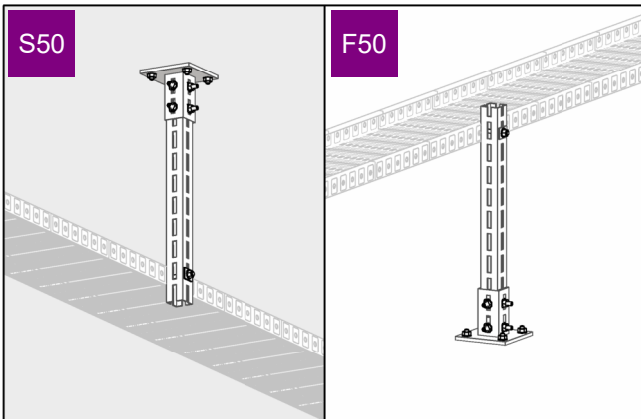

FIX SP50-2072 "S" BASEPLATE TO SP50 STRUT WITH 6-SPBOLT-S45-M10. ALIGN SP50 GAL LENGTH TO CABLE TRAY AND FIX THROUGH STRUT WITH M10 DOME HEAD BOLT TO TRAY AND LARGE PLATE WASHER TO STRUT. FIX BASEPLATE TO FLOOR/SOFFIT WITH 4-M10 ANCHORS.

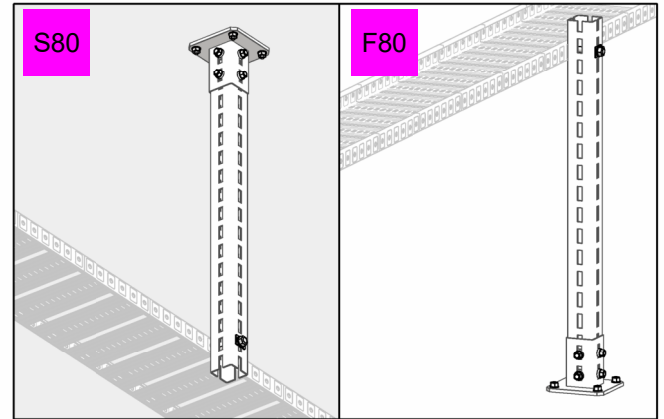

FIX SP80-2072 BASEPLATE TO SP80 STRUT WITH 6-SPBOLT-M12S. ALIGN SP80 GAL LENGTH TO CABLE TRAY AND FIX THROUGH STRUT WITH M12 DOME HEAD BOLT TO TRAY AND LARGE PLATE WASHER TO STRUT. FIX BASEPLATE TO FLOOR / SOFFIT WITH 4-M16 ANCHORS.

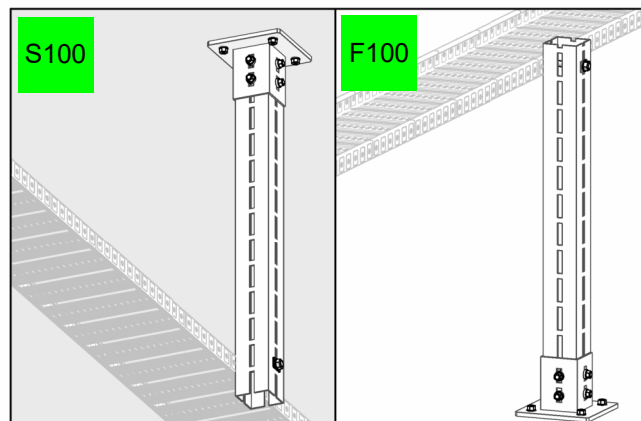

FIX SP100-2072 BASEPLATE TO SP100 STRUT WITH 6-SPBOLT-M12S. ALIGN SP100 GAL LENGTH TO CABLE TRAY AND FIX THROUGH STRUT WITH M12 DOME HEAD BOLT TO TRAY AND LARGE PLATE WASHER TO STRUT. FIX BASEPLATE TO FLOOR / SOFFIT WITH 4-M16 ANCHORS.

S50	SUPA 50	F50	SUPA 50	M10 SPBOLTS; M10 HILTI HST4 OR M10 ICCONS FM753 ANCHORS.
S80	SUPA 80	F80	SUPA 80	M12S SPBOLTS AND M16 HILTI HST4 OR M16 ICCONS THRU-BOLT ULTRA PRO ANCHORS.
S100	SUPA 100	F100	SUPA 100	M12S SPBOLTS; M16 HILTI HST4 OR M16 ICCONS THRU-BOLT ULTRA PRO ANCHORS.
SOFFIT-FIXED		FLOOR-FIXED		

BASEPLATE AND ANCHOR

S50 **F50**

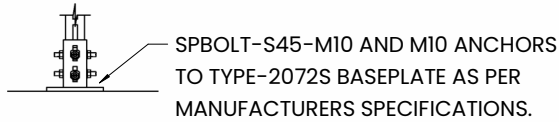

S80 **F80**
S100 **F100**

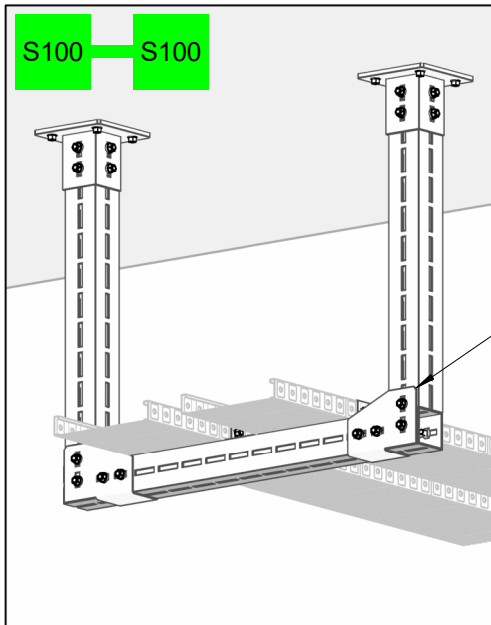
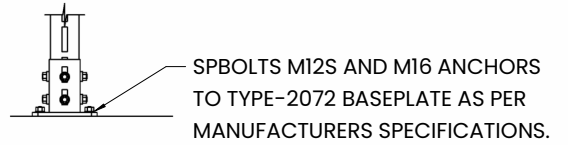

8-SPBOLTS THROUGH BRACKET INTO SUPA TRAPEZE/HURDLE

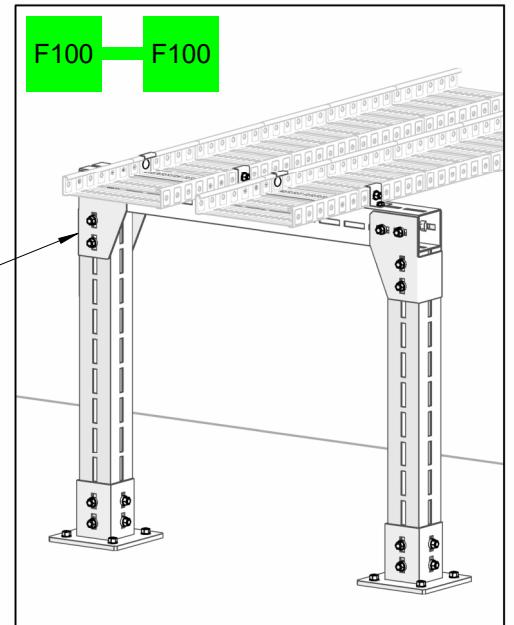

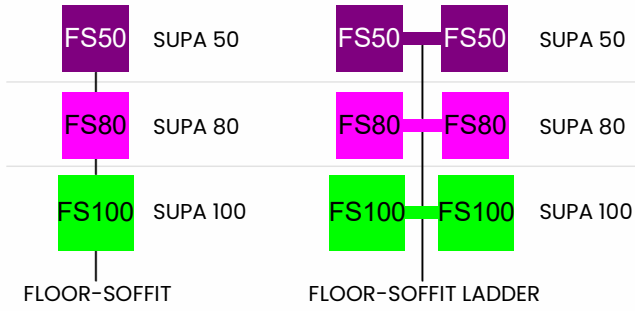

M10 SPBOLTS; M10 HILTI HST4 OR M10 ICCONS FM753 ANCHORS; SP50-2484 CORNER BRACKETS FOR LADDER.

M12S SPBOLTS; M16 HILTI HST4 OR M16 ICCONS THRU-BOLT ULTRA PRO ANCHORS; SP80-2484 CORNER BRACKETS FOR LADDER.

M12S SPBOLTS; M16 HILTI HST4 OR M16 ICCONS THRU-BOLT ULTRA PRO ANCHORS; SP100-156 SHOE BRACKETS FOR LADDER.

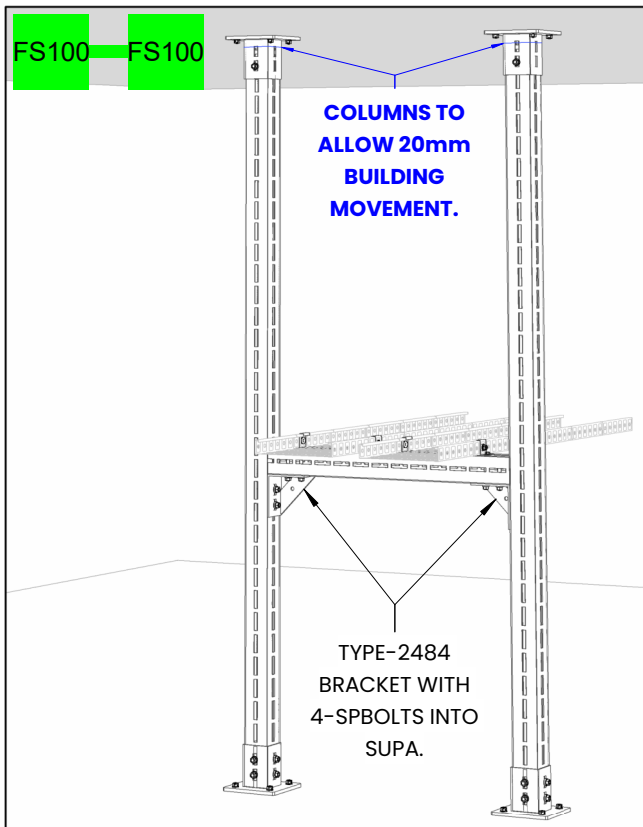
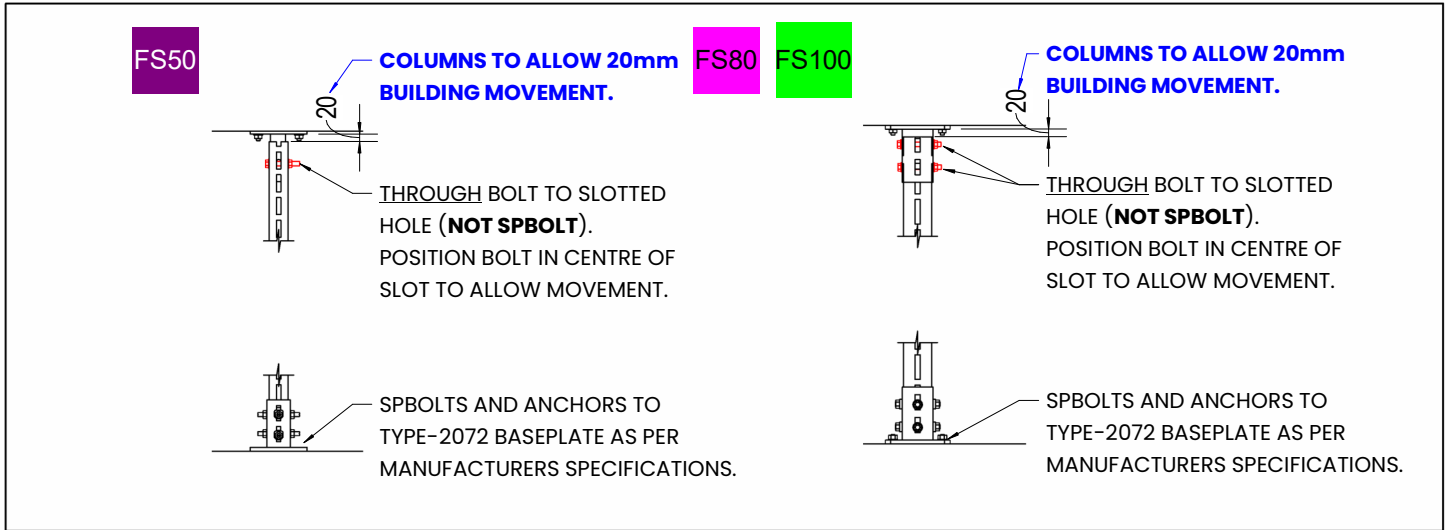

INSTALLATION SHOWN CAN BE APPLIED TO SP50, SP80 & SP100. REFER TO SPBOLT, ANCHOR AND BRACKET SPECIFICATIONS ABOVE.

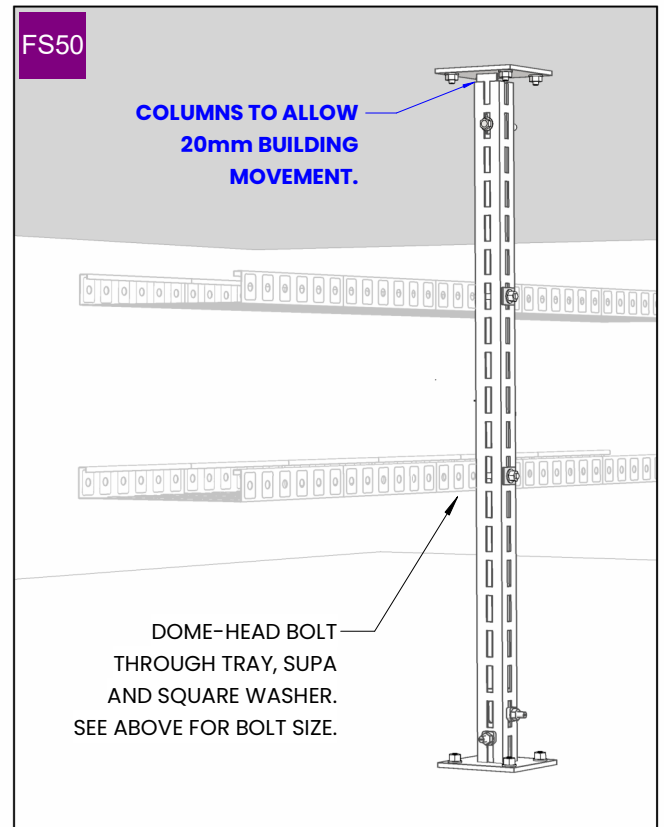

INSTALLATION SHOWN CAN BE APPLIED TO SP50, SP80 & SP100. REFER TO SPBOLT, ANCHOR AND BRACKET SPECIFICATIONS ABOVE.

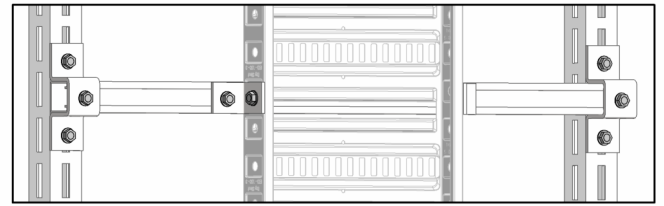
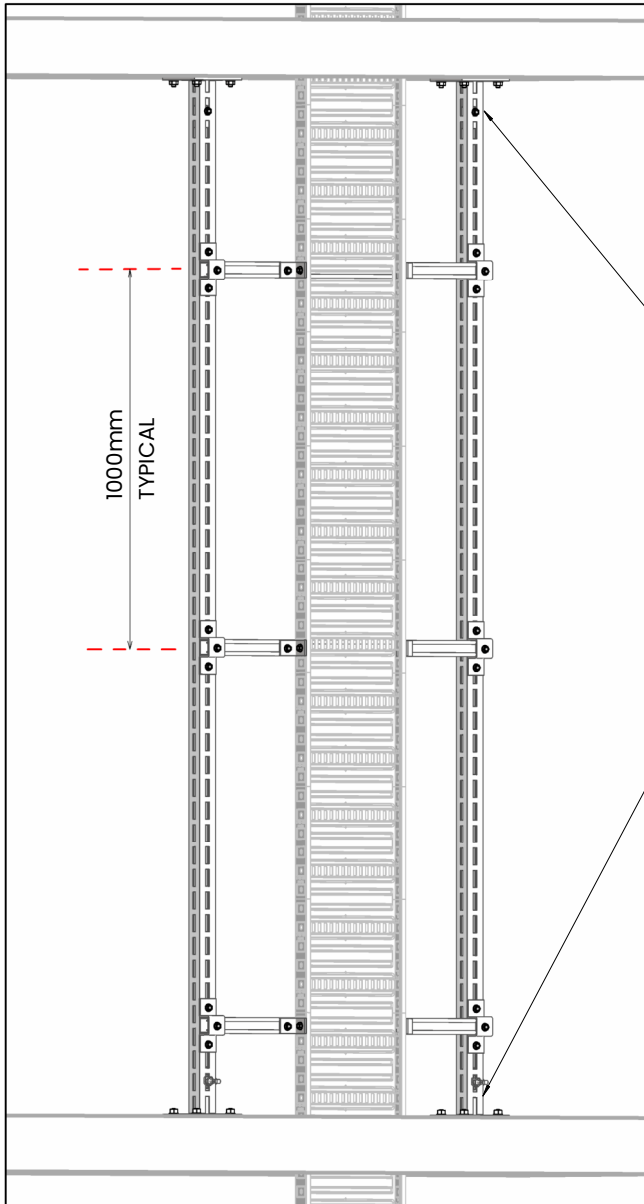

VARIATION OF ELECTRICAL RISER SUPPORT. FIX TRAY TO 41mm STRUT WITH FM1026 ANGLE BRACKETS, M10 BOLTS AND CHANNEL NUTS. FIX 41mm STRUT TO SP50 POST AT 1000mm CENTRES WITH FM1047 BRACKETS WITH 2-M10 BOLTS TO SP50 AND 1-M10 BOLT AND CHANNEL NUT TO 41mm STRUT.

TOP SP50-2072 BASEPLATES REQUIRE A SLIDE JOINT TO ALLOW FOR VERTICAL SLAB MOVEMENT. PROVIDE 2-M10x70mm BOLTS THROUGH BRACKET AND ALLOW 20mm CLEARANCE BETWEEN THE END OF THE POST AND THE SOFFIT SP50-2072, ANCHORS: M12 HILTI HST4, ICCONS FM753 OR APPROVED EQUIVALENT, THROUGH BOLT ETC

BOTTOM SP50-2072 BASEPLATES WITH 4- SEISMIC RATED ANCHORS AND 2-SPBOLT M10.

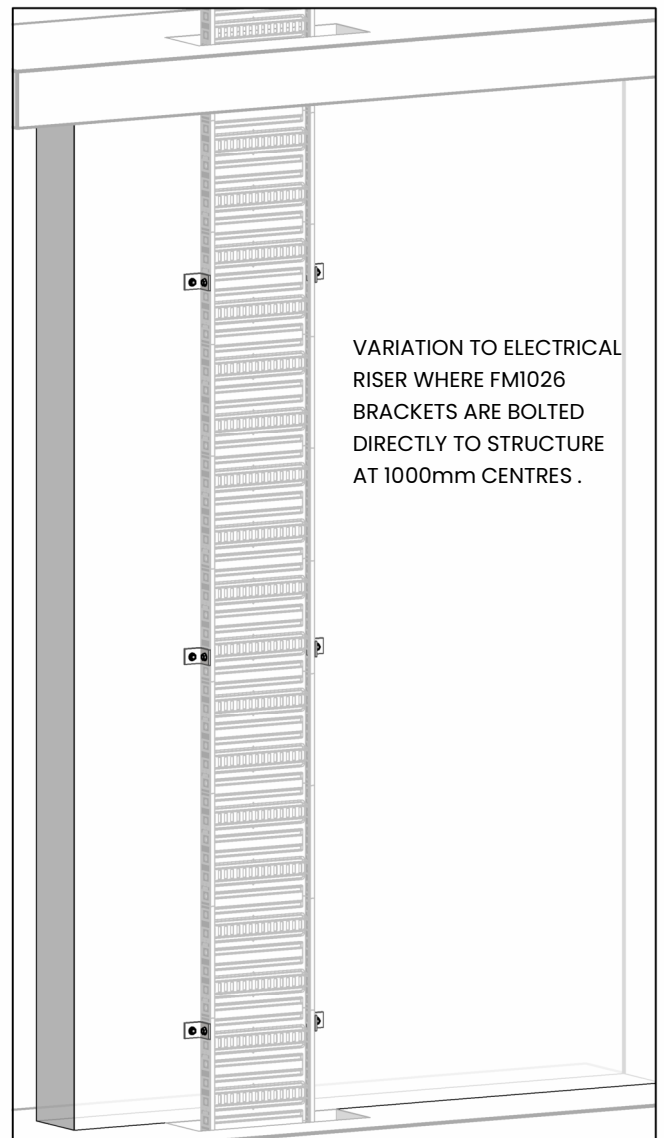

VARIATION TO ELECTRICAL RISER WHERE FM1026 BRACKETS ARE BOLTED DIRECTLY TO STRUCTURE AT 1000mm CENTRES .

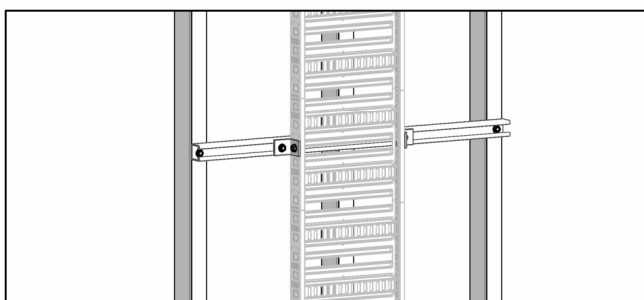

VARIATION TO ELECTRICAL RISER TO STUD WALL WHERE FM1026 BRACKETS ARE BOLTED TO 41mm STRUT WHICH IS BOLTED/SCREW-FIXED TO THE WALL STUDS AT 1000mm CENTRES.
WALL LINING OMITTED FOR CLARITY.

INSTALL ALL CABINETS AS PER MANUFACTURER'S INSTALLATION INSTRUCTIONS. THIS DRAWING IS FOR THE PURPOSES OF SEISMIC RESTRAINT AND IS IN ADDITION TO THE MANUFACTURER'S INSTALLATION INSTRUCTIONS.

OPTION 1

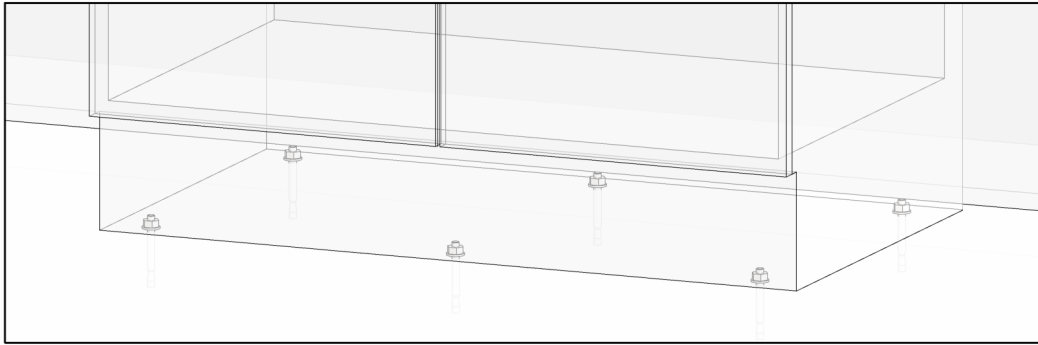

M10 SEISMIC ANCHORS TO CABINET BASE, PROVIDED THERE IS ACCESS AND THE MANUFACTURERS INSTALLATION INSTRUCTIONS ARE FOLLOWED. - NO FURTHER FIXING REQUIRED (INCLUDING TOP)

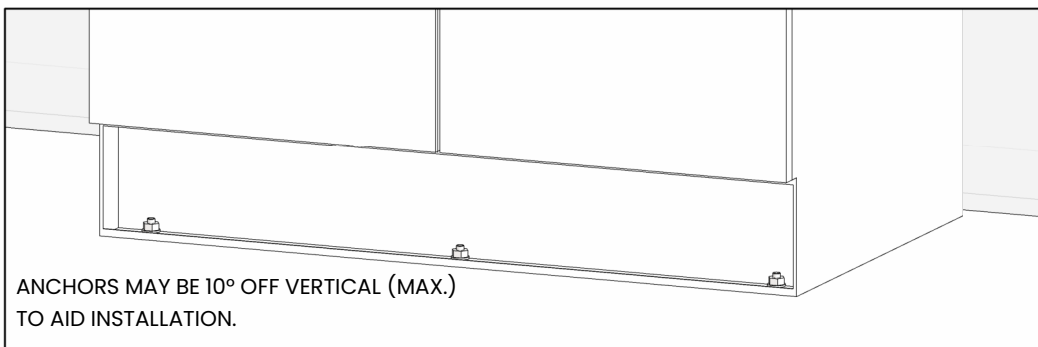

ANCHORS MAY BE 10° OFF VERTICAL (MAX.) TO AID INSTALLATION.

M10 SEISMIC ANCHORS TO CABINET BASE, WHERE PROVISION IS PROVIDED & MANUFACTURERS INSTALLATION INSTRUCTIONS ARE FOLLOWED. QTY TO SUIT, 900 CENTRES MAX., QTY - 2 MIN.

OPTION 2
(IN COMBINATION
WITH TOP FIXING
OPTIONS ON
FOLLOWING
PAGES)

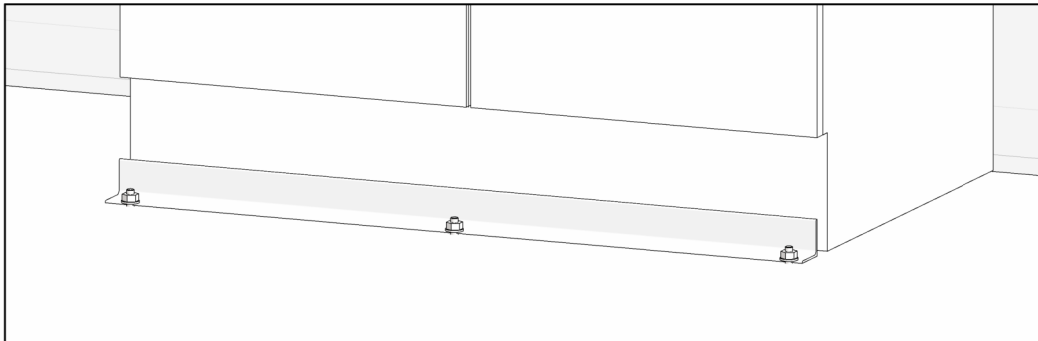

EQUAL ANGLE (50x2.5 EA) TO ENTIRE WIDTH OF CABINET. (OPTION - SIMILAR TO 2 SIDES) M10 SEISMIC ANCHORS TO EA. QTY TO SUIT, 900 CENTRES MAX., QTY - 2 MIN. 12g TEK SCREWS TO CABINET. QTY TO SUIT, 450 CENTRES MAX., QTY - 3 MIN.

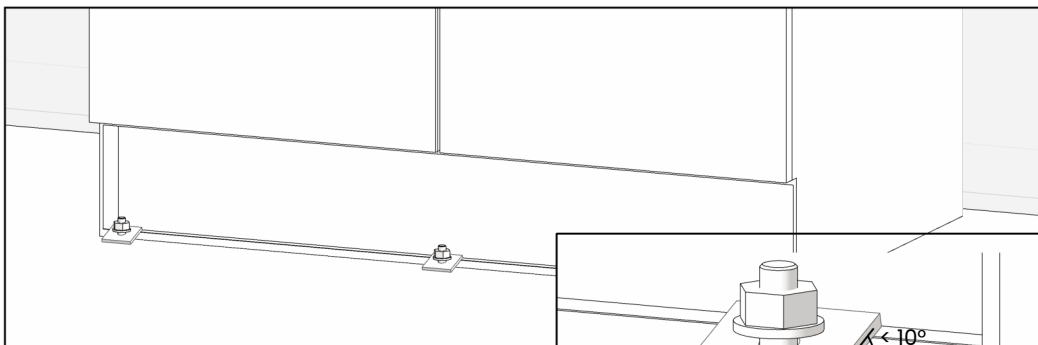

M10 SEISMIC ANCHORS (OPTION - SIMILAR TO 2 SIDES) TO CABINET, EACH WITH P1064 SQUARE WASHER (OR EQUIVALENT). QTY TO SUIT, 900 CENTRES MAX., QTY - 2 MIN.

ANCHORS MAY BE 10° OFF VERTICAL (MAX.) TO AID INSTALLATION.

CONTACT **KUSCH** FOR PROJECT SPECIFIC ASSESSMENT ABOVE 10°.

SEISMIC RESTRAINT OF SWITCHBOARD CABINET (TOP) STRUCTURAL WALL

INSTALL ALL CABINETS AS PER MANUFACTURER'S INSTALLATION INSTRUCTIONS. THIS DRAWING IS FOR THE PURPOSES OF SEISMIC RESTRAINT AND IS IN ADDITION TO THE MANUFACTURER'S INSTALLATION INSTRUCTIONS.

OPTION 1

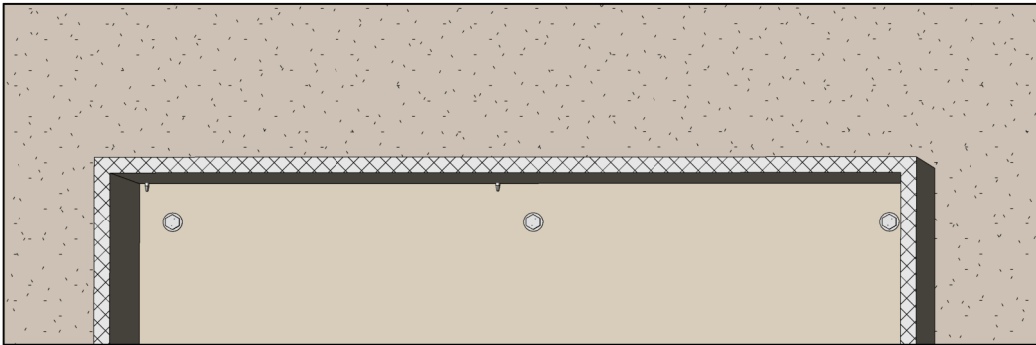

M10 BOLTS OR SEISMIC ANCHORS AT HIGH LEVEL. QUANTITY TO SUIT. 900 CENTRES MAX., MIN QTY - 2. (PROVIDED PROVISION IS MADE ACCORDING TO MANUFACTURER'S INSTALLATION DIRECTION AND ACCESS IS AVAILABLE)

OPTION 2

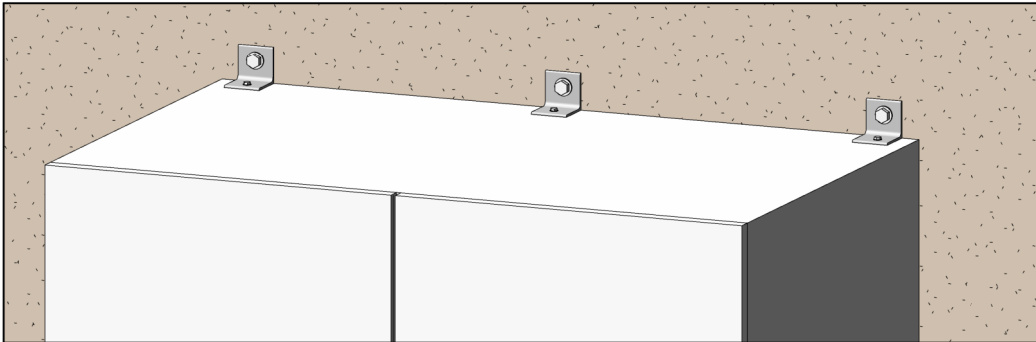

EQUAL ANGLE (50x2.5 EA) 50mm LONG (TYPICAL). M10 BOLT OR SEISMIC ANCHOR TO STRUCTURE, 900 CENTRES MAX., MIN. QTY - 2. 12g TEK SCREWS TO CABINET, 450 CENTRES MAX., MIN. QTY - 2.

OPTION 3

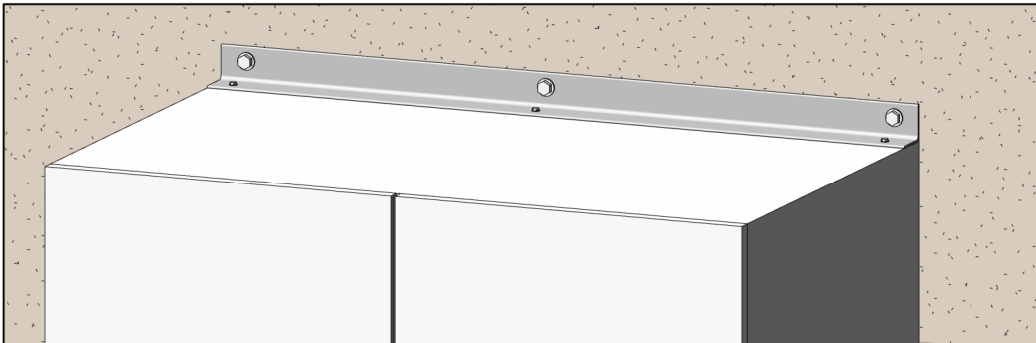

EQUAL ANGLE (50x2.5 EA) TO WIDTH OF CABINET. M10 BOLT OR SEISMIC ANCHOR TO STRUCTURE, 900 CENTRES MAX., MIN. QTY - 2. 12g TEK SCREWS TO CABINET, 450 CENTRES MAX., MIN. QTY - 2.

OPTION 4

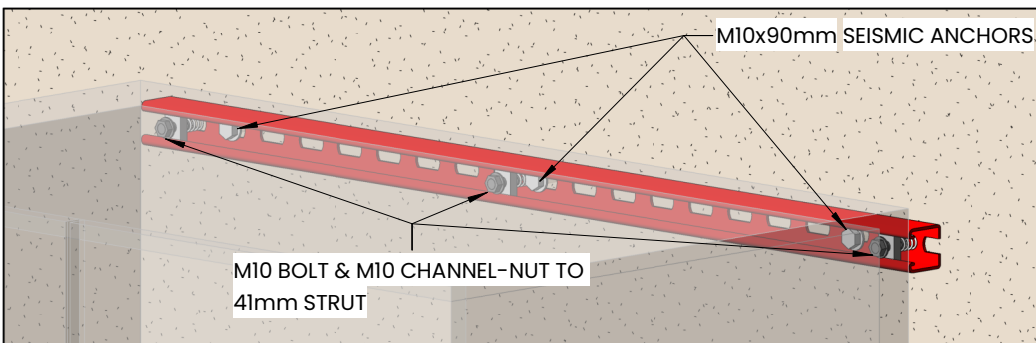

41mm STRUT TO WIDTH OF CABINET. M10 BOLT OR SEISMIC ANCHOR TO STRUCTURE, 900 CENTRES MAX., MIN. QTY - 2. M10 BOLTS & CHANNEL-NUTS TO CABINET, 450 CENTRES MAX., MIN. QTY - 2.

SEISMIC RESTRAINT OF SWITCHBOARD CABINET (TOP) STUD WALL

INSTALL ALL CABINETS AS PER MANUFACTURER'S INSTALLATION INSTRUCTIONS. THIS DRAWING IS FOR THE PURPOSE OF SEISMIC RESTRAINT AND IS IN ADDITION TO THE MANUFACTURER'S INSTALLATION INSTRUCTIONS.

STRUCTURAL DESIGN OF STUD WALL MUST INCLUDE THE LOAD FROM PROPOSED SWITCHBOARD CABINET.

OPTION 1

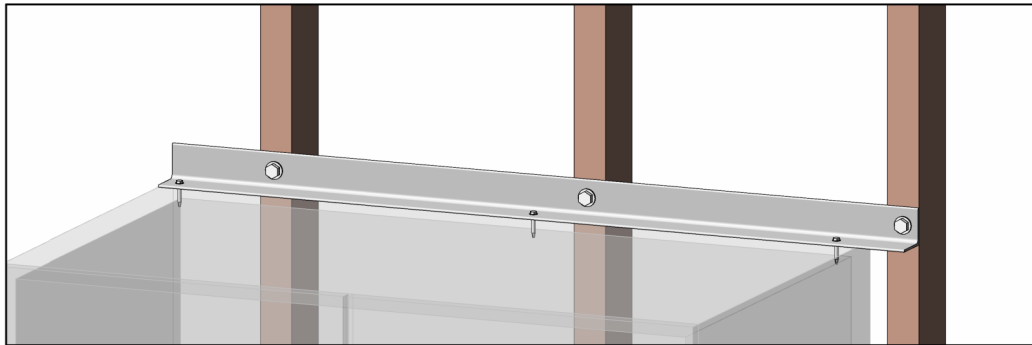

EQUAL ANGLE (50x2.5 EA) TO RUN THE ENTIRE LENGTH OF CABINET (WALL SHEETING OMITTED FOR CLARITY).

12g TEK SCREWS TO CABINET, 450 CENTRES MAX., MIN. QTY - 2.

- TIMBER STUD - M10 COACH BOLTS TO EACH TIMBER STUD.
- STEEL STUD - 12g TEK SCREW TO EACH STEEL STUD.

OPTION 2

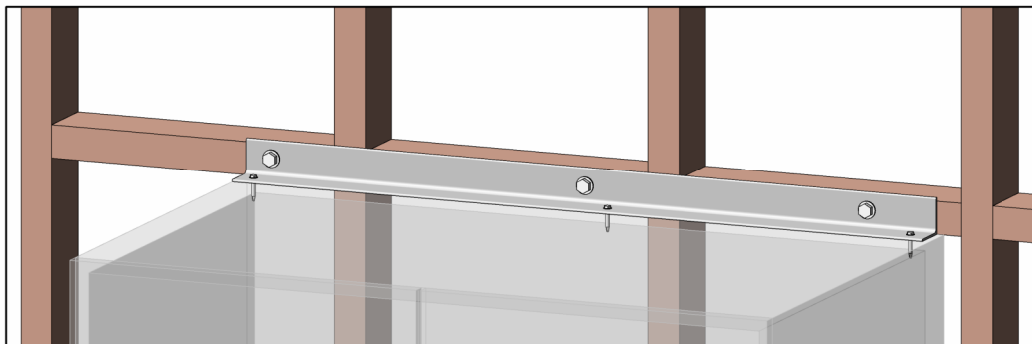

EQUAL ANGLE (50x2.5 EA) TO RUN THE ENTIRE LENGTH OF CABINET (WALL SHEETING OMITTED FOR CLARITY).

12g TEK SCREWS TO CABINET, 450 CENTRES MAX., MIN. QTY - 2.

- TIMBER NOGGING/TRIMMING - M10 COACH BOLTS, QTY TO SUIT 900 CENTRES MAX., QTY - 2 MIN.
- STEEL NOGGING/TRIMMING - 12g TEK SCREWS, QTY TO SUIT 450 CENTRES MAX., QTY - 2 MIN.

OPTION 3



OPTION 4



FIXING DIRECTLY THROUGH CABINET (WALL SHEETING OMITTED FOR CLARITY).

STUDS AT 450 CENTRES - SINGLE ROW OF M10 COACH BOLTS (TIMBER STUDS)/12g TEK SCREWS (STEEL STUDS) QTY-2 Min.

STUDS AT 600 CENTRES - DOUBLE ROW OF M10 COACH BOLTS (TIMBER STUDS)/12g TEK SCREWS (STEEL STUDS) QTY-4 MIN.

OPTION 1

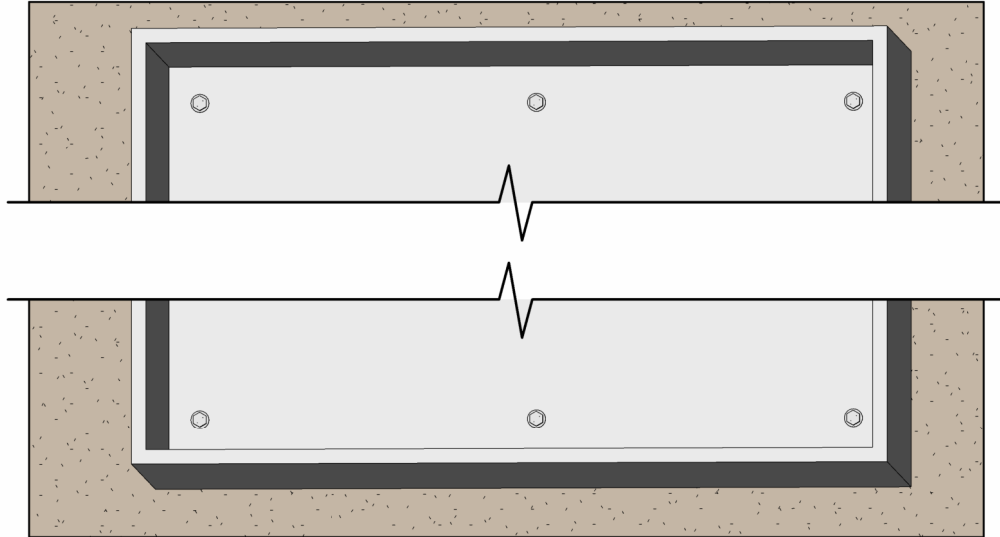

M10 BOLTS OR SEISMIC ANCHORS TO STRUCTURAL WALL (EXCLUDES STUD WALL). QTY TO SUIT, 900MM CENTRES MAX. QTY - 4 MIN.

OPTION 2

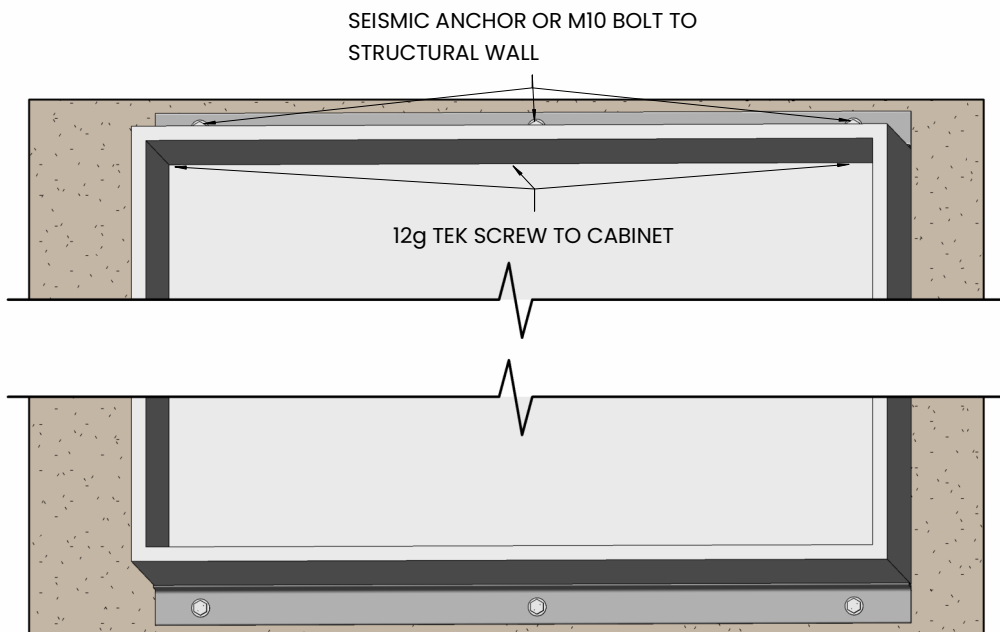

EQUAL ANGLE (50x2.5 EA) TO WIDTH OF CABINET AS PER DETAIL ON PAGE 16 FOR STRUCTURAL WALL OR DETAIL ON PAGE 17 FOR STUD WALL.

STRUCTURAL DESIGN OF STUD WALL MUST INCLUDE THE LOAD FROM PROPOSED SWITCHBOARD CABINET.



KUSCH
Engineered.

w: kusch.com.au

e: design@kusch.com.au

p: 1300 10 22 30

Victoria: Head Office

36-38 Hollonds St, Mount Beauty,
Victoria 3699

Queensland

Level 10, 333 Ann St, Brisbane,
Queensland 4000

New South Wales

Level 6, 241 Commonwealth St,
Surry Hills, New South Wales 2010

Adelaide

72-76 Edmund Ave, Unley,
South Australia 5061